

# UNIWELD SMARTTECH<sup>®</sup> FUSION<sup>™</sup>

## PRO KIT

Wireless Professional Tools  
INSTRUCTION MANUAL

ENGLISH



REFRIGERATION & AIRSIDE PERFORMANCE  
VACUUM TEST ■ NITROGEN PRESSURE TEST

- USFTB Uniweld Fusion Tool Bag (1)
- USWPG Wireless Pressure Gauge (2)
- USWPP Wireless Psychrometer Probe (2)
- USWTC Wireless Temperature Clamp (2)
- USWVG Wireless Vacuum Gauge (1)
- USWTP Wireless Temperature Probe (1)
- USWMPK Wireless Manometer Kit (1)

Includes: Wireless Manometer Probe (2)

Magnetic Static Pressure Probe 90° (2)

9" Pressure Tube (2), Flexible Transparent Tubing (2)

Brass Fitting (2) Step Connector (2),

Step Connector Tubing (2), Stepped T Fitting (2)

Batteries AAA (6), Soft Case (1)

FC  
IC  
CE



1-800-323-2111

www.uniweld.com • email: info@uniweld.com

## TABLE OF CONTENTS

<b>IMPORTANT SAFETY WARNINGS</b>	3
<b>SYMBOLS</b>	4
<b>USWPP WIRELESS PSYCHROMETER PROBE</b>	5
<b>USWPG WIRELESS PRESSURE GAUGE</b>	6
<b>USWTC WIRELESS TEMPERATURE CLAMP</b>	7
<b>USWTP WIRELESS TEMPERATURE PROBE</b>	8
<b>USWVG WIRELESS VACUUM GAUGE</b>	9
<b>USWMPK WIRELESS MANOMETER KIT</b>	10
<b>APP OVERVIEW</b>	13-27
Nitrogen Pressure Test	13
Nitrogen Pressure Test Tool Connection	14
Vacuum Test	15
Vacuum Test Tool Connection	17
Wireless Scale	18
Wireless Scale Tool Connection	19
Refrigeration Side Performance	20
Refrigeration Side Tool Connection	21
Choosing a Refrigerant	22
Air Side Performance	23
Air Side Tool Connection	24
Units Screen	25
User Info Screen	25
Report Screen	26
Support Screen	27
<b>FCC/IC INFORMATION</b>	28
<b>DISPOSAL</b>	29
<b>CLEANING</b>	29
<b>STORAGE</b>	29
<b>WARRANTY</b>	30

### **WARNING**

Read entire Safety Notes section regarding potential hazard and proper instructions before using these probes. In this manual the word “**WARNING**” is used to indicate conditions or actions that may pose physical hazards to the user. The word “**CAUTION**” is used to indicate conditions or actions that may damage the instruments.

### **WARNING**

To ensure safe operation and service of these probes, follow these instructions. Failure to observe these warnings can result in severe injury or death.

### **WARNING**

Not exceed the following maximum pressure limits.

USWVG Wireless Vacuum Gauge maximum over pressure 700 psi.

USWPG Wireless Pressure Gauge maximum over pressure 1000 psi.

### **WARNING**

- Do not open these probes to replace batteries while the probes are connected.
- To avoid false readings, replace batteries if a low battery indicator appears.
- Do not use these probes if they appear damaged.
- Always adhere to national and local safety codes. Use proper personal protective equipment (PPE).

### **WARNING**

These probes are designed for trade professionals who are familiar with the hazards of their trade.

Observe all recommended safety procedures that include proper lockout utilization and use of personal protective equipment that includes safety glasses, gloves and flame resistant clothing.

## SYMBOLS

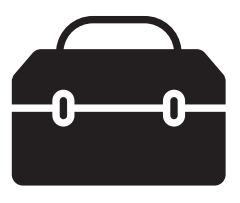

**TOOLBOX**

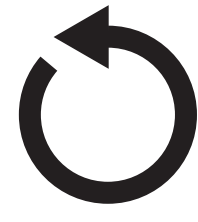

**REFRESH**

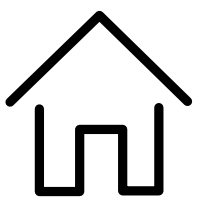

**HOME**



**WEBPAGE**



**REPORTING**



**CONNECTION STRENGTH**

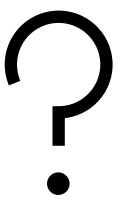

**SUPPORT**



**BATTERY**

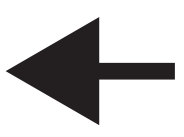

**BACK**



**FORGET TOOL**

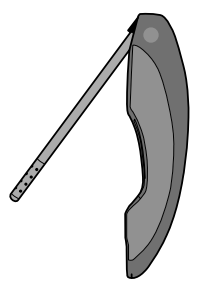

**USWPP**



**SAVE**

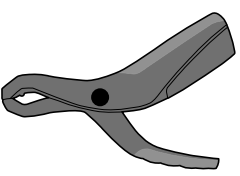

**USWTC**



**UNITS**

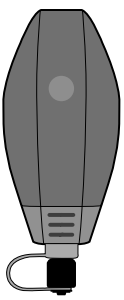

**USWVG**

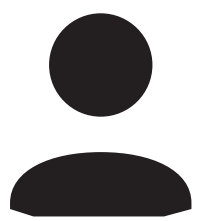

**USER**

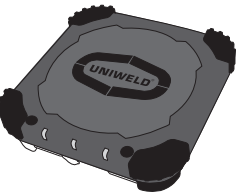

**DIGITAL SCALE**

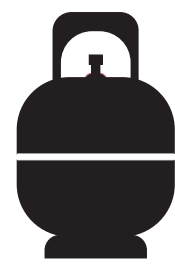

**REFRIGERANT TANK**

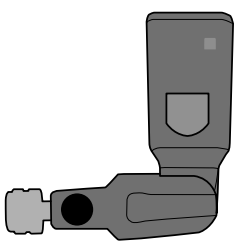

**USWPG**



**EDIT ICON**

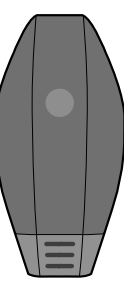

**USWTP**



**CLOCK**

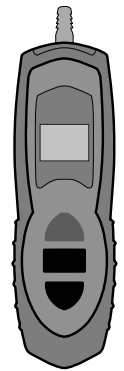

**USWMP**

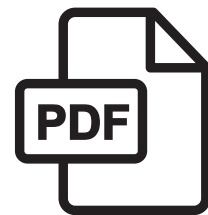

**PDF ICON**

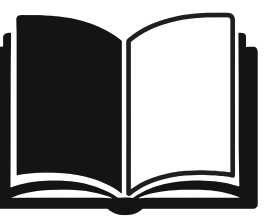

**USER MANUAL**



**DELETE/CLEAR ALL**



**VIEW LICENSES**



**VIDEO**

# USWPP WIRELESS PSYCHROMETER PROBE

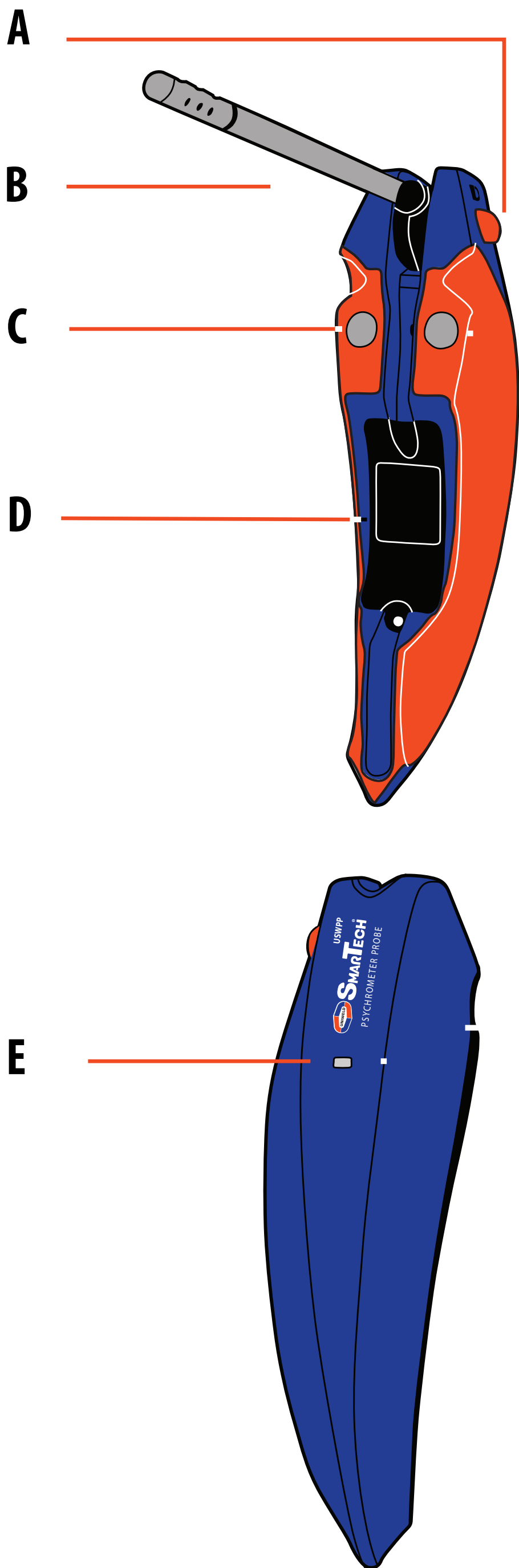

## GENERAL SPECIFICATIONS

- **Temperature Range:** 14° to 158°F (-10° to 70°C)
- **Temperature Accuracy:** ±0.5°F (0.3°C)
- **Relative Humidity Range:** 14° to 140°F (-10° to 60°C)
- **Relative Humidity Resolution:** 30% to 85% RH
- **Relative Humidity Accuracy:** ±3% 20% to 80% otherwise ±5%
- **Operating Temperature:** 14° to 158°F (-10° to 70°C)
- **Storage Temperature:** 13° to 185°F (-25° to 85°C)
- **Operating Humidity:** 20% RH to 80% RH
- **Dimensions:** 6.84 in x 1.93 in x 1.53 in (17.4 cm x 4.9 cm x 3.9 cm)
- **Item Weight:** 4.4 oz (125 g)
- **Certification:** CE Conformity, FCC/IC
- **Battery Type:** (AAA) 2
- **Battery Life:** 100+ hours

- A.** Lock Button: Press to open or close probe  
Pressing the lock button and opening the probe powers it on
- B.** 1/4" diameter probe
- C.** Magnetic Mount
- D.** Battery Cover
- E.** Light: Blinks **GREEN** when probe is powered on. Blinks **RED** when low battery\*

**! CAUTION:** Press down Lock Button to release probe. Failure to do so may break probe and is not covered under warranty.

**\*NOTE:** Low battery indicator is also in the "Tool Connection" screen of the app.

**! CAUTION:** Take care not to lose the screws when opening battery compartments

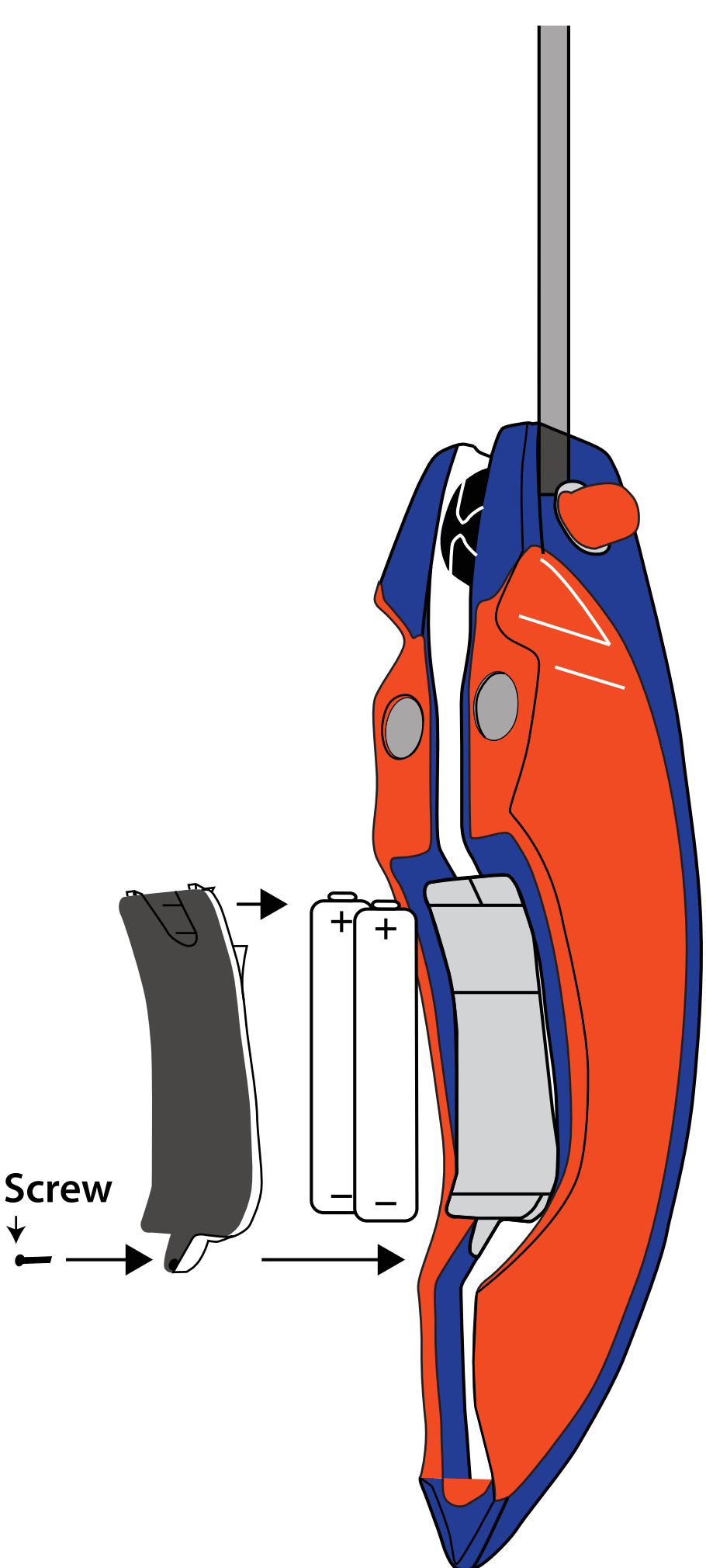

- Remove battery cover.
- Replace the old batteries with 2 new (AAA) batteries.
- Replace the battery cover.

## GENERAL SPECIFICATIONS

- **Range:** 10 to 725 PSIG
- **Resolution:** 0.1 PSI
- **Accuracy:** 0.5% F.S. (at 25°C ±3°C) Total 1% F.S. 32° to 158°F (0° to 70°C)
- **Operating Temperature:** 14° to 158°F (-10° to 70°C)
- **Storage Temperature:** 13° to 185°F (-25° to 85°C)
- **Operating Humidity:** 30% RH to 85% RH
- **Over-range:** 1000 PSI
- **Dimensions:** 6.70 in x 1.56 in x 1.44 in (17 cm x 4 cm x 3.7 cm)
- **Item Weight:** 7.4 oz (210 g)
- **Certification:** CE Conformity, FCC/IC
- **Battery Type:** (AA) 2
- **Battery Life:** 100+ hours

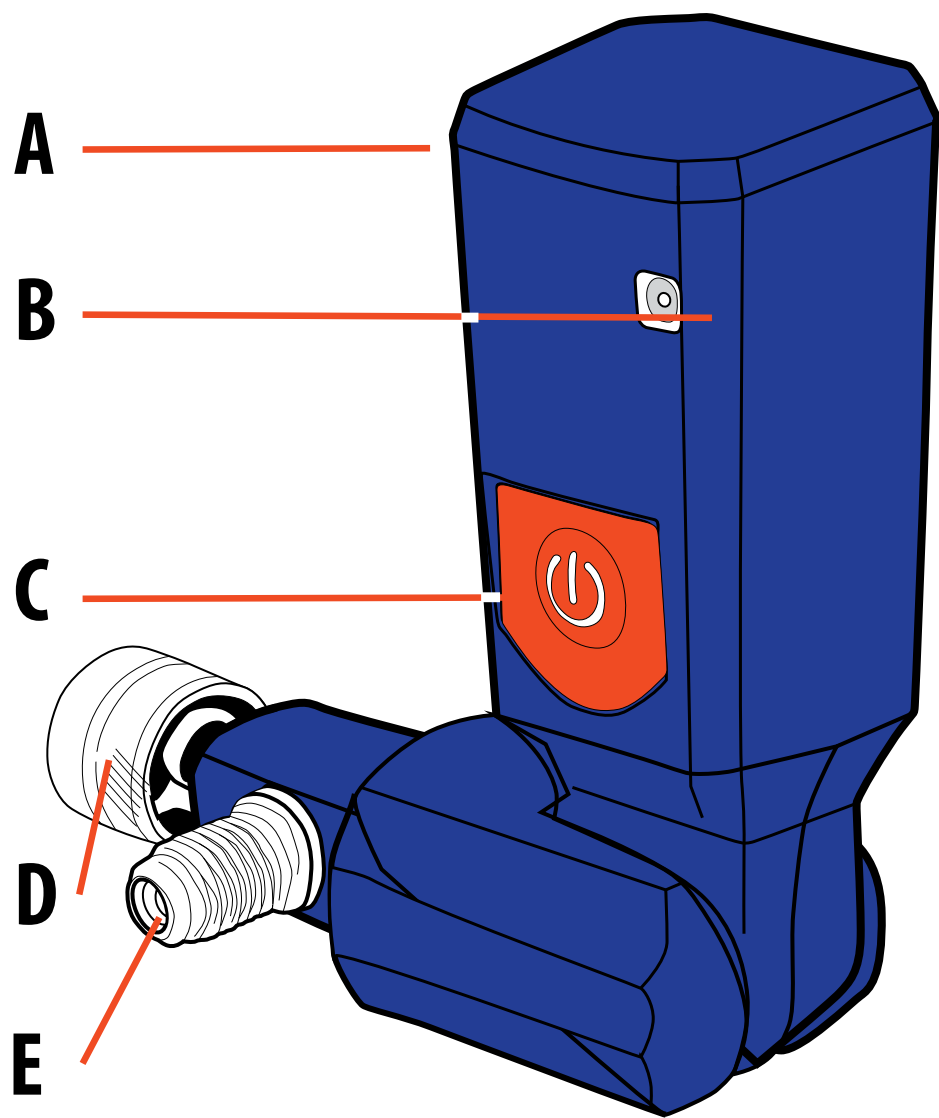

- A.** Battery cover
- B.** Light: Blinks **GREEN** when probe is powered on and blinks **RED** when low battery.\*
- C.** Power Button: Hold for one second to power on
- D.** 1/4" pressure connector
- E.** 1/4" pass-through connector

**⚠ CAUTION:** Max over pressure is 1000 PSI

**\*NOTE:** Low battery indicator is also in the "Tool Connection" screen of the app.

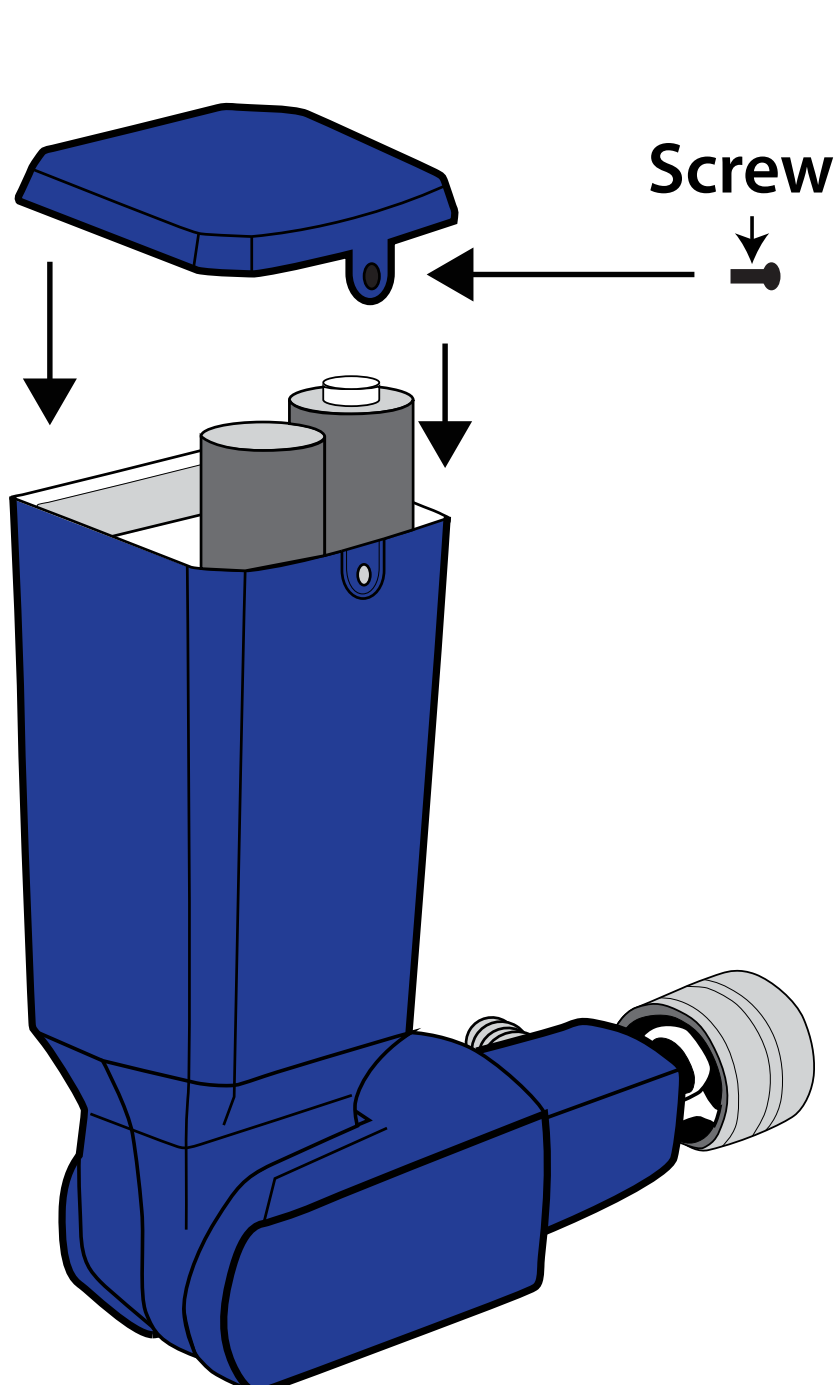

Battery level  displayed in the tool connection screen to the right of each probe connected.

**⚠ CAUTION:** Take care not to lose the screws when opening battery compartments

- Remove battery cover.
- Replace the old batteries with 2 new (AAA) batteries.
- Replace the battery cover.

## GENERAL SPECIFICATIONS

- **Range:** 32° to 176°F (0° to 80°C)
- **Resolution:** 0.1°F
- **Accuracy:** ±(0.6°F (0.3°C))
- **Response Time:** <30 sec.
- **Operating Temperature:** 14° to 158°F (-10° to 70°C)
- **Storage Temperature:** 13° to 185°F (-25° to 85°C) Dimensions: 5.66 in x 3.81 in x 1.10 in (14.4 cm x 9.7 cm x 2.8 cm)
- **Item Weight:** 2.1 oz (60 g)
- **Jaw Opening:** Maximum pipe diameter is 1.5 in. (3.8cm)
- **Certification:** CE Conformity, FCC/IC
- **Battery Type:** (AA) 1
- **Battery Life:** 100+ hours

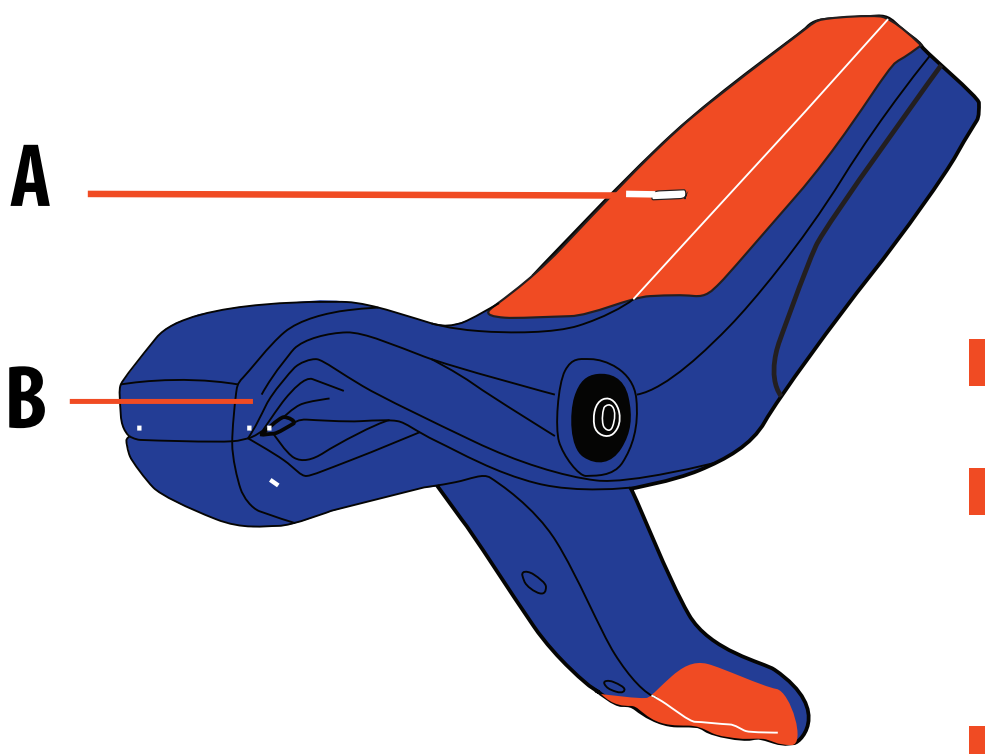

- A.** Light: Blinks **GREEN** when probe is powered on and blinks **RED** when low battery. \* Opening the clamp powers it on
- B.** Temperature sensor

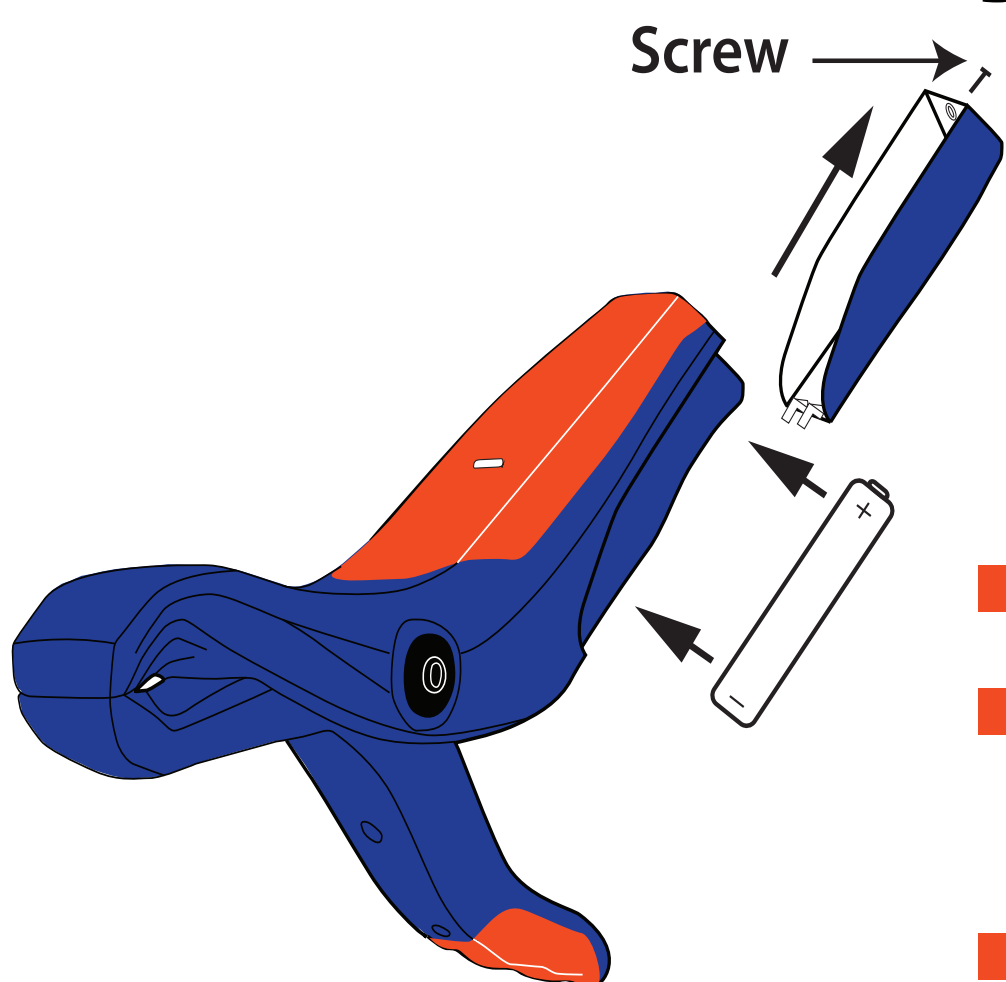

**\*NOTE:** Low battery indicator is also in the "Tool Connection" screen of the app.

- Remove battery cover.
- Replace the old batteries with 1 new (AA) battery.
- Replace the battery cover.

**⚠ Caution:** Take care not to lose the screws when opening battery compartments

## GENERAL SPECIFICATIONS

- **Range:** 32° to 180°F (0° to 82°C)
- **Resolution:** 0.1"
- **Accuracy:** ± 2°F (1°C)
- **Operating Temperature:** 14° to 158°F (-10° to 70°C)
- **Storage Temperature:** 13° to 185°F (-25° to 85°C)
- **Operating Humidity:** 30% to 85% RH
- **Dimensions:** 4.75 in x 2.37 in x 1.5 in
- **Item Weight:** 5.4 oz (153 g)
- **Certification:** FCC/IC, CE Conformity
- **Battery Type:** (AA) 2
- **Battery Life:** 100+ hours

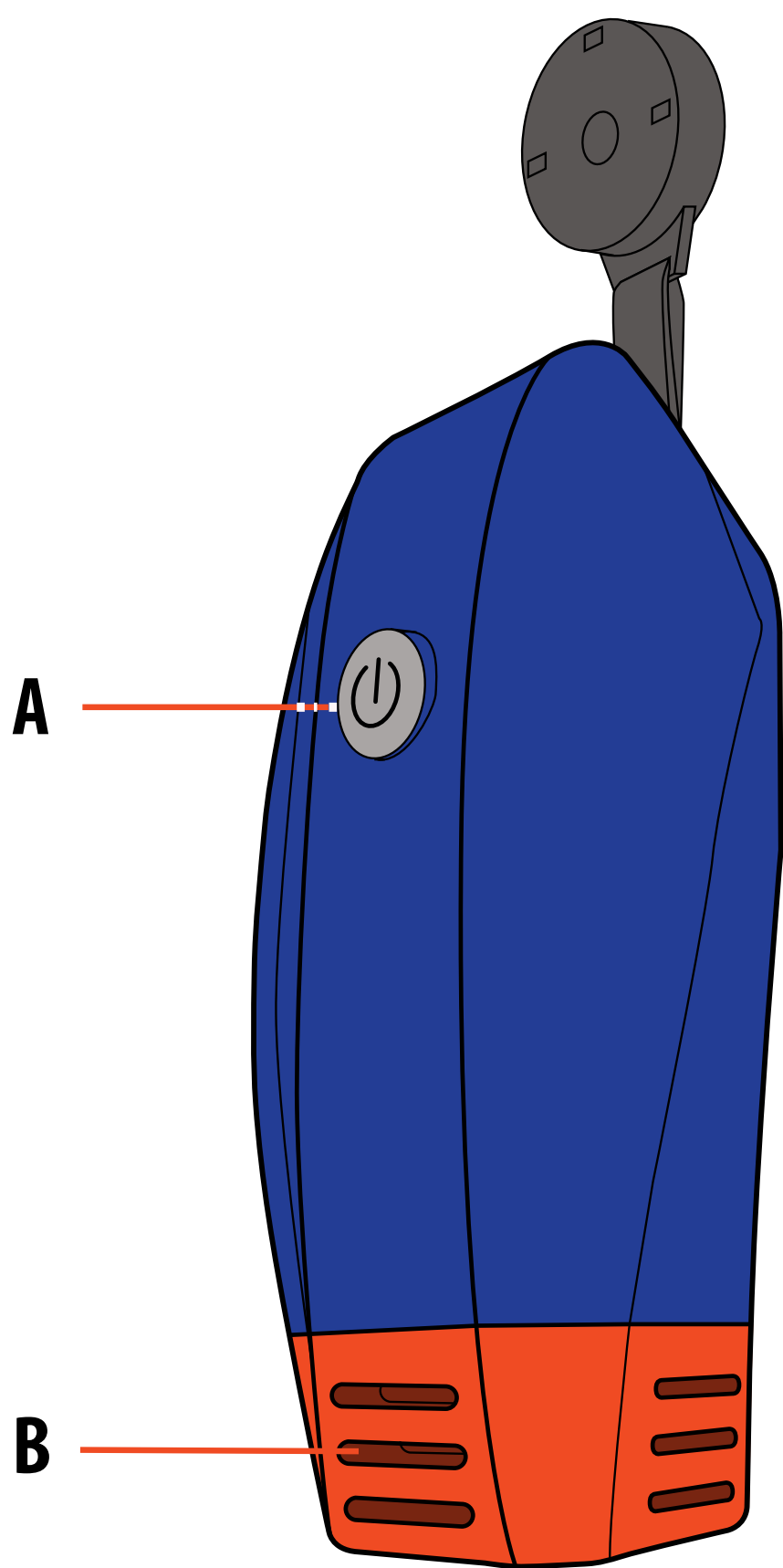

- A.** Light: Blinks **GREEN** when probe is powered on and blinks **RED** when low battery. \*
- B.** Temperature Sensor
- C.** Magnetic Hanger Strap

**\*NOTE:** Low battery indicator is also in the "Tool Connection" screen of the app.

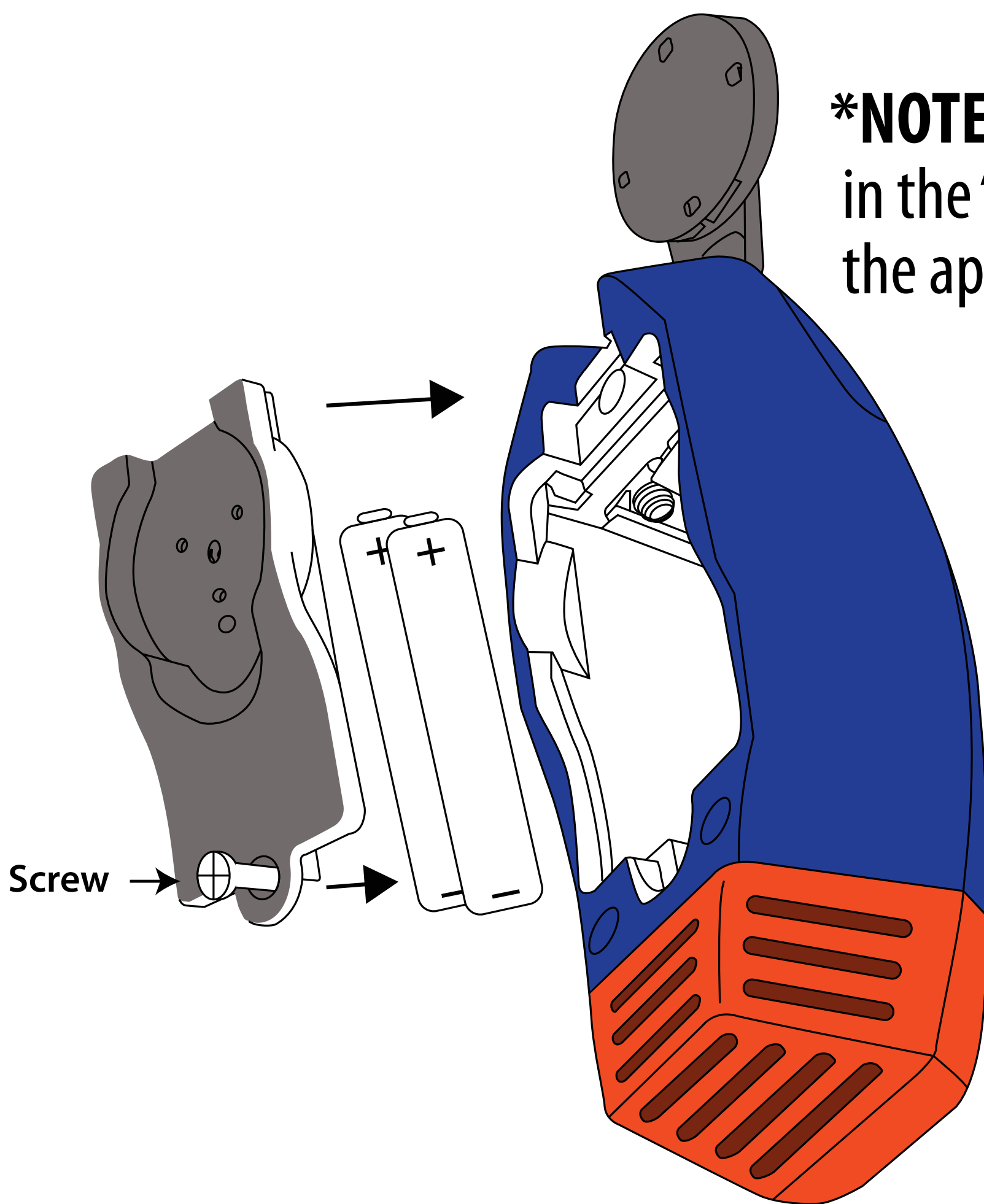

- Remove battery cover.
- Replace the old batteries with 2 new (AA) battery.
- Replace the battery cover.

## GENERAL SPECIFICATIONS

- **Range:** 0 - 20,000 Microns
- **Resolution:** 1 micron
- **Accuracy:**  $\pm 5\%$  rdg  $\pm 5$  microns
- **Operating Temperature:** 4° to 158°F (-10° to 70° C)
- **Storage Temperature:** 13° to 185°F (-25° to 85° C)
- **Operating Humidity:** 30% to 85% RH
- **Dimensions:** 5.6 in x 2.37 in x 1.5 in
- **Item Weight:** 4.2 oz (119 g)
- **Certification:** FCC/IC, CE Conformity
- **Battery Type:** (AA) 2
- **Battery Life:** 100+ hours

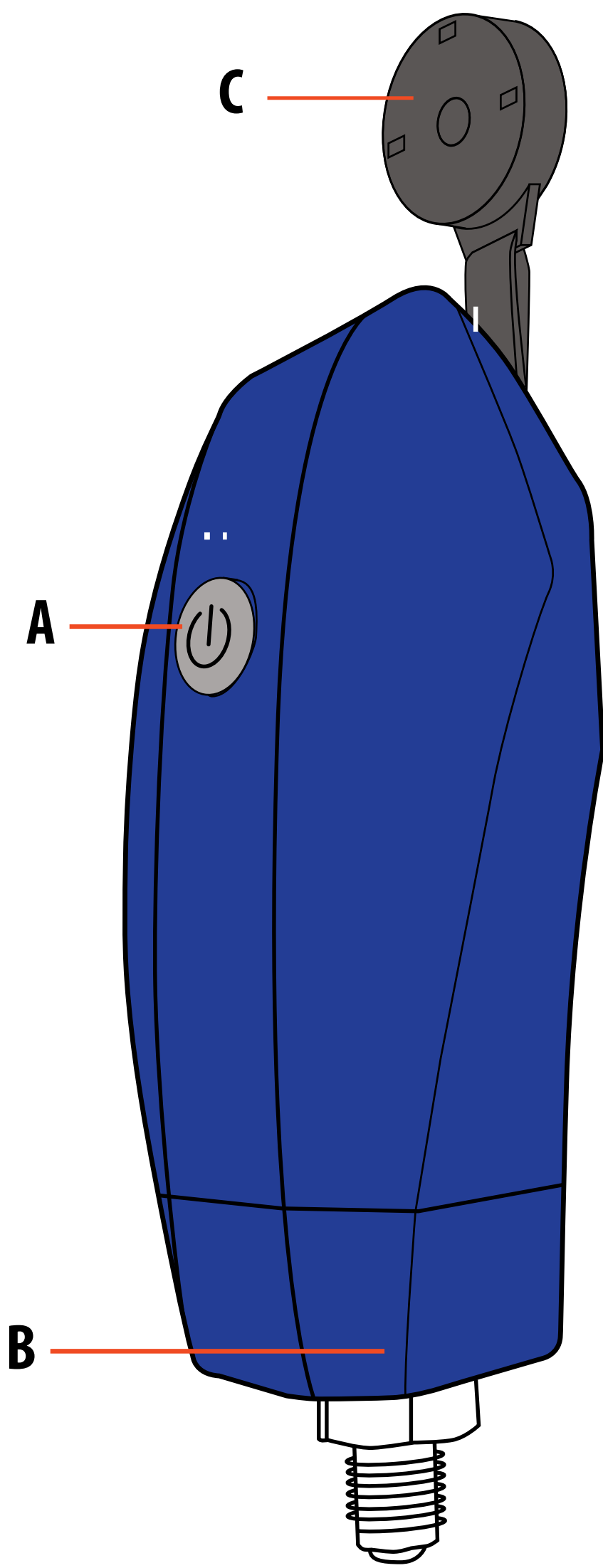

- A.** Light: Blinks **GREEN** when probe is powered on and blinks **RED** when low battery. \*
- B.** Temperature Sensor
- C.** Magnetic Hanger Strap

**!** Maximum over pressure is **700 PSI**

**\*NOTE:** Low battery indicator is also in the "Tool Connection" screen of the app.

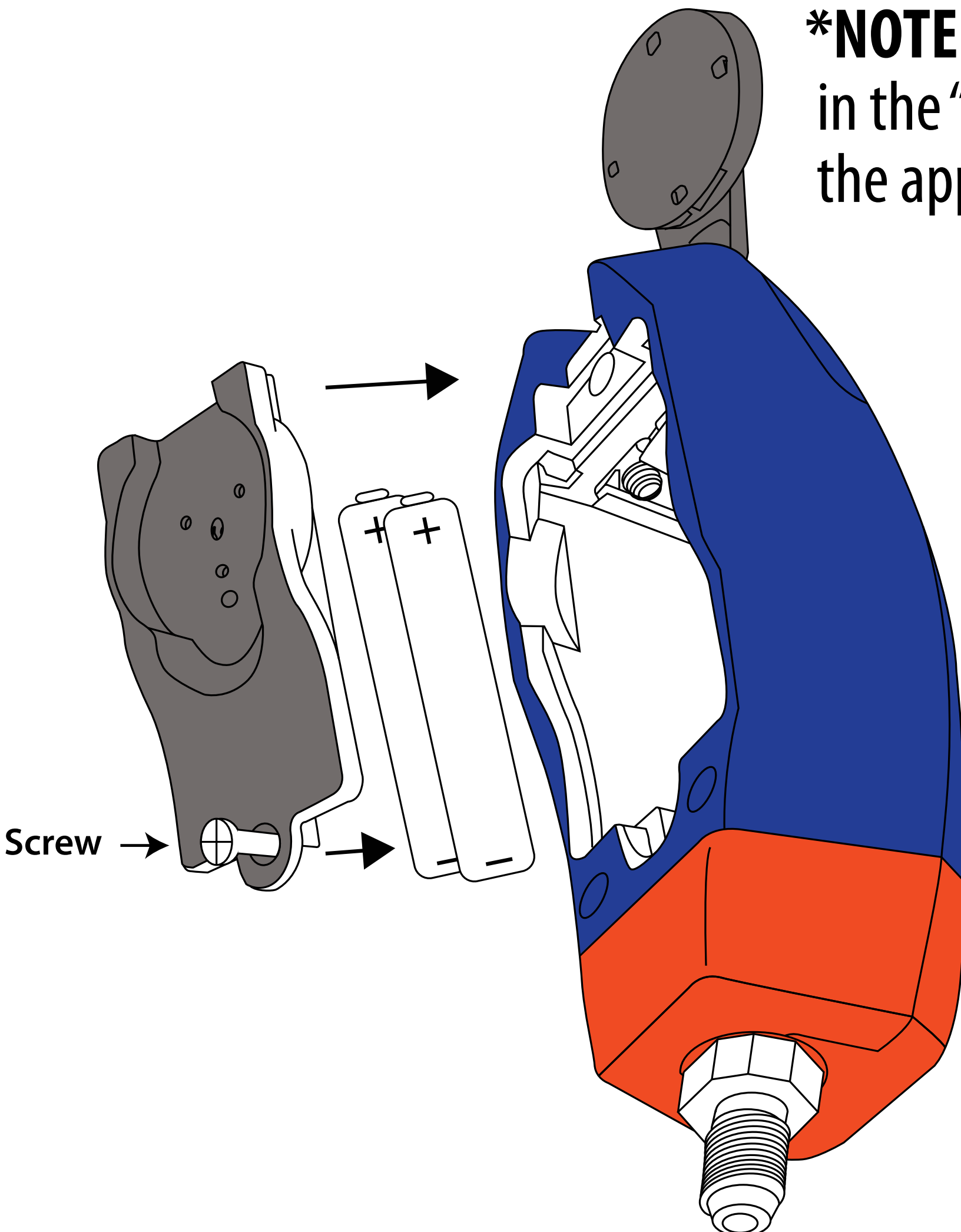

- Remove battery cover.
- Replace the old batteries with 2 new (AA) battery.
- Replace the battery cover.

**\*NOTE:** For sensor cleaning maintenance see page 19.

## GENERAL SPECIFICATIONS

- **Accuracy:**  $\pm 0.03 < 3$  inwg,  $\pm 1\%$  rdg  $> 3$  inwg
- **Resolution:** 0.01" (0 to 99.99 inwg)
- **Units of measure:** mbar, bar, psi, inwg, mmwg, Pa, kPa
- **Operation Temperature:** 32°F to 104°F (0°C to 40°C)
- **Storage temperature:** 14°F to 122°F (-10°C to 50°C)
- **Accuracy Temperature:** 64°F to 82°F (18°C to 28°C)
- **Humidity:** Max RH 80% for temperatures up to 88°F (31°C) decreasing linearly to 50% RH at 104°F (40°C)
- **Operating Altitude:** Up to 2000 meters
- **Pollution Degree:** 2
- **Overvoltage Category:** 1
- **Over-range:** OL is displayed
- **APO:** Auto power off after 30 minutes
- **Dimensions:** 2.5 x 9 x 1.2 in (51x150.5 x33.4 mm)
- **Weight:** 6.5 oz (180g)
- **Calibration interval:** One year
- **Certifications:** CE, FCC, RoHS, REACH Compliant
- **Rated Power:** 4.5 VDC (3X1.5 VDC, LR03, AAA type batteries)

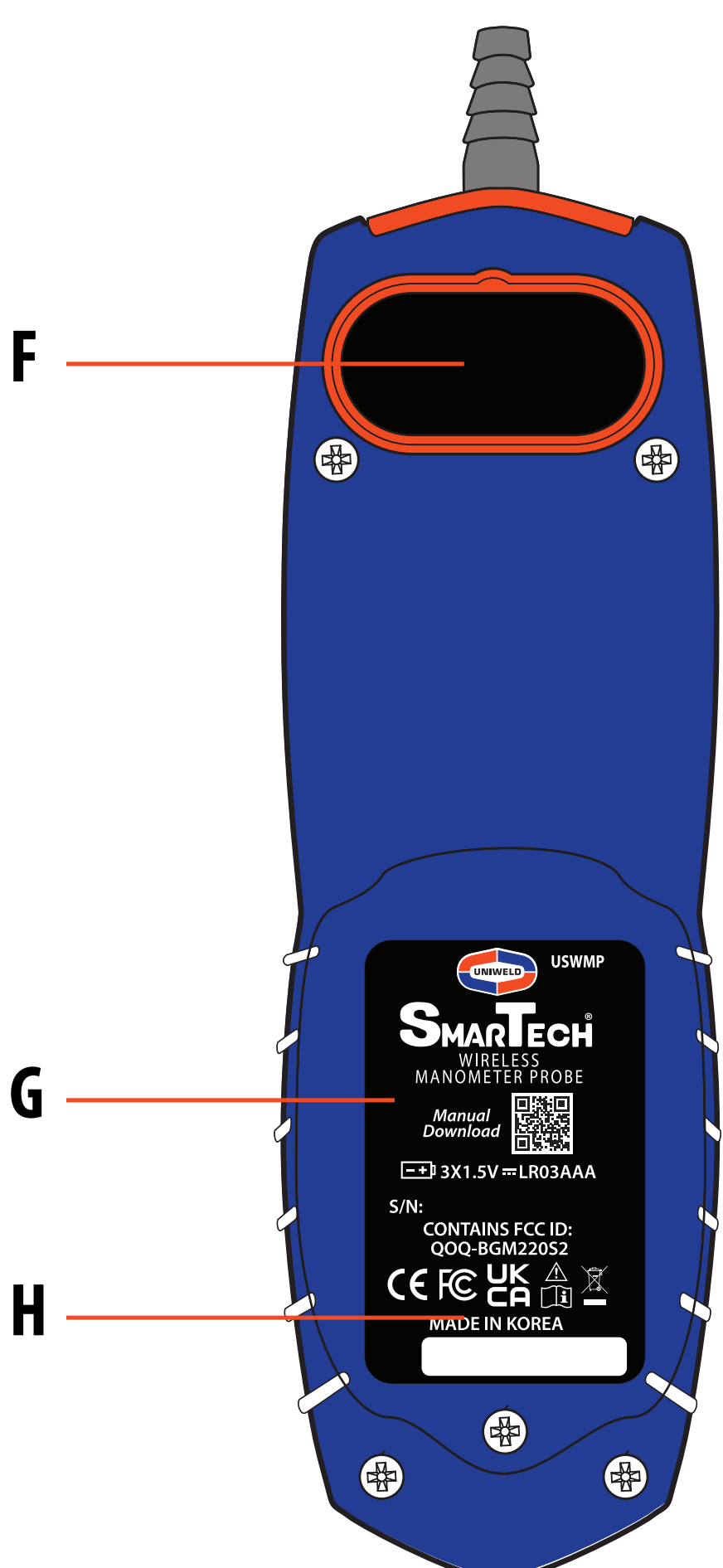
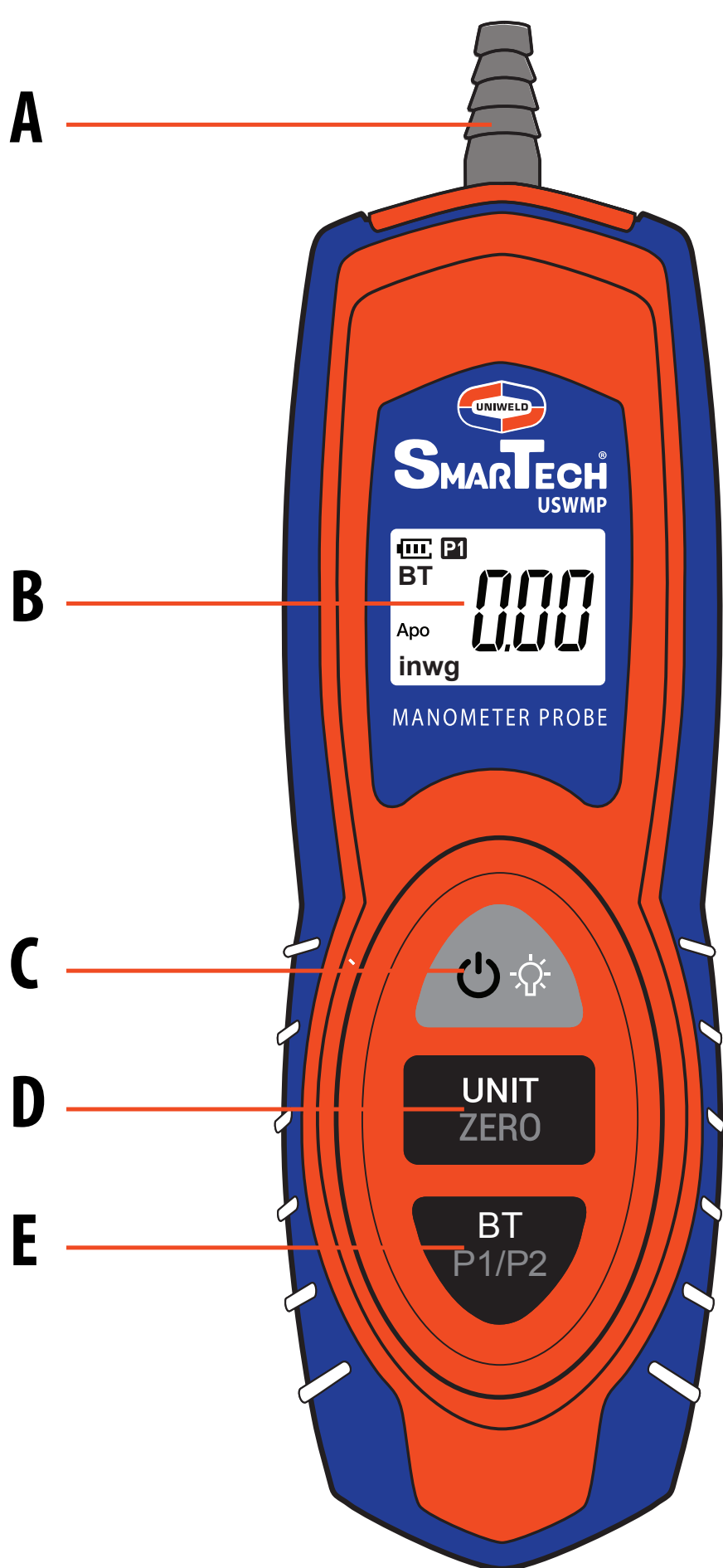

### A. Pressure Sensor Inputs

- Pressure input

### B. Display with Backlight

- **Battery:** When battery is too low for safe operation, The Low Battery indicator will display . See Battery Replacement section at the end of this manual.

### C. Power/Backlight Button (Red)

- Press to Power on manometer. Press to power off manometer.
- Press and hold to turn on display backlight. Back light has a 60 second duration.

### D. Unit/Zero Button

- 6 selectable units of measurement.
- To zero the manometer, press and hold.

## USWMPK WIRELESS MANOMETER KIT

### E. Wireless Connection Button

- Press BT button to activate wireless connection to a device.
- Press and Hold the P1/P2 button to change P1 or P2.

### F. Magnetic Mount

### G. Battery Compartment Cover

### H. Serial Number

## BATTERY REPLACEMENT

- Battery Replacement.
- When low battery indicator icon displays.
- Loosen the screw. Captive screw is used to insure screw does not get lost. (Phillips-head screw)
- Remove battery cover.
- Replace the 3 AAA batteries.
- Replace battery cover, tighten screw.
- Dispose used batteries properly.

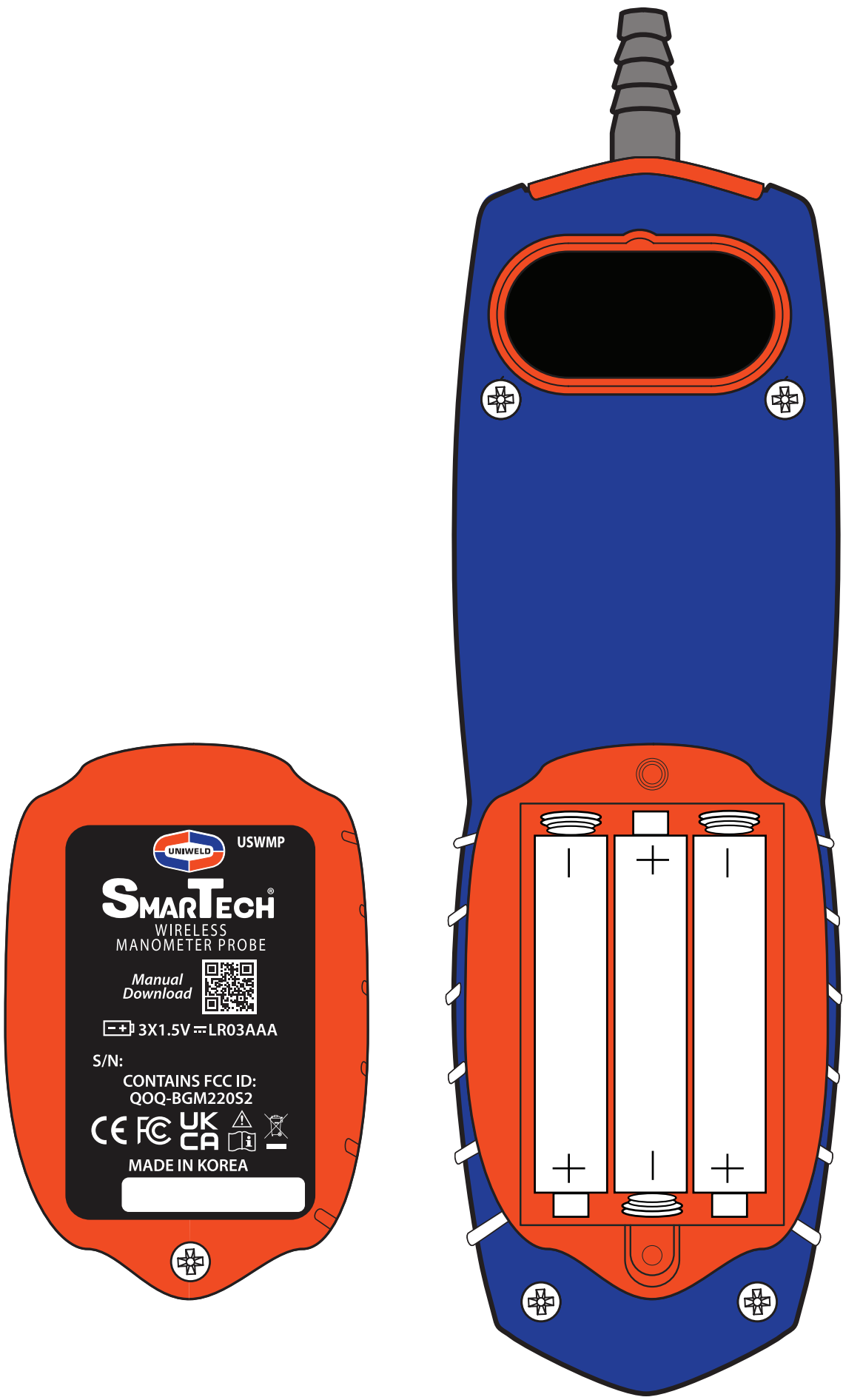

## STATIC PRESSURE

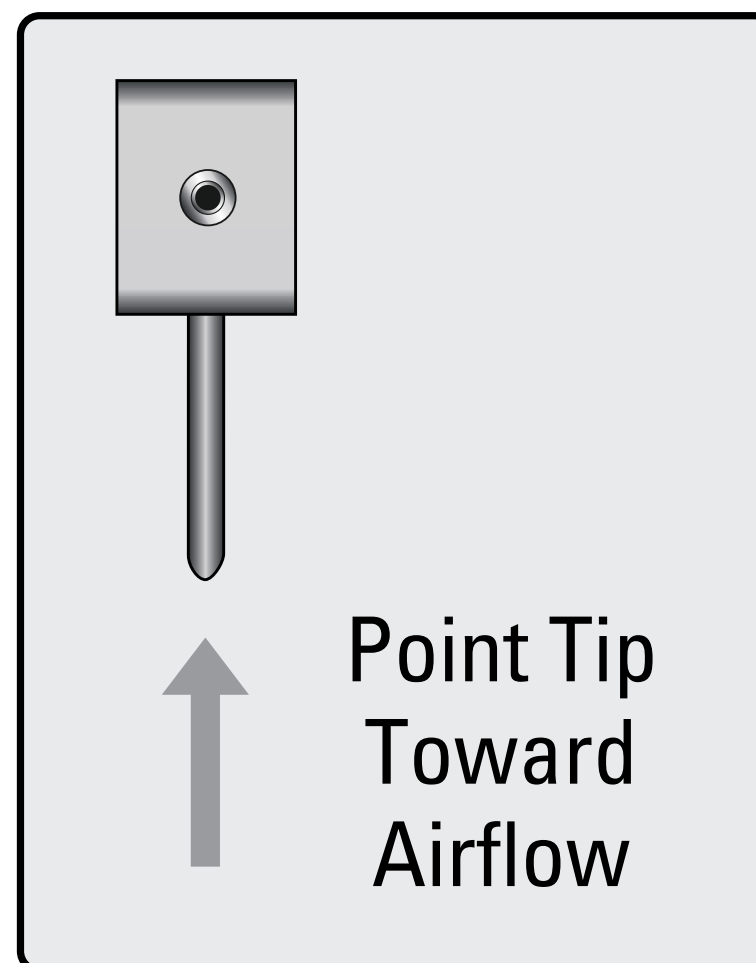
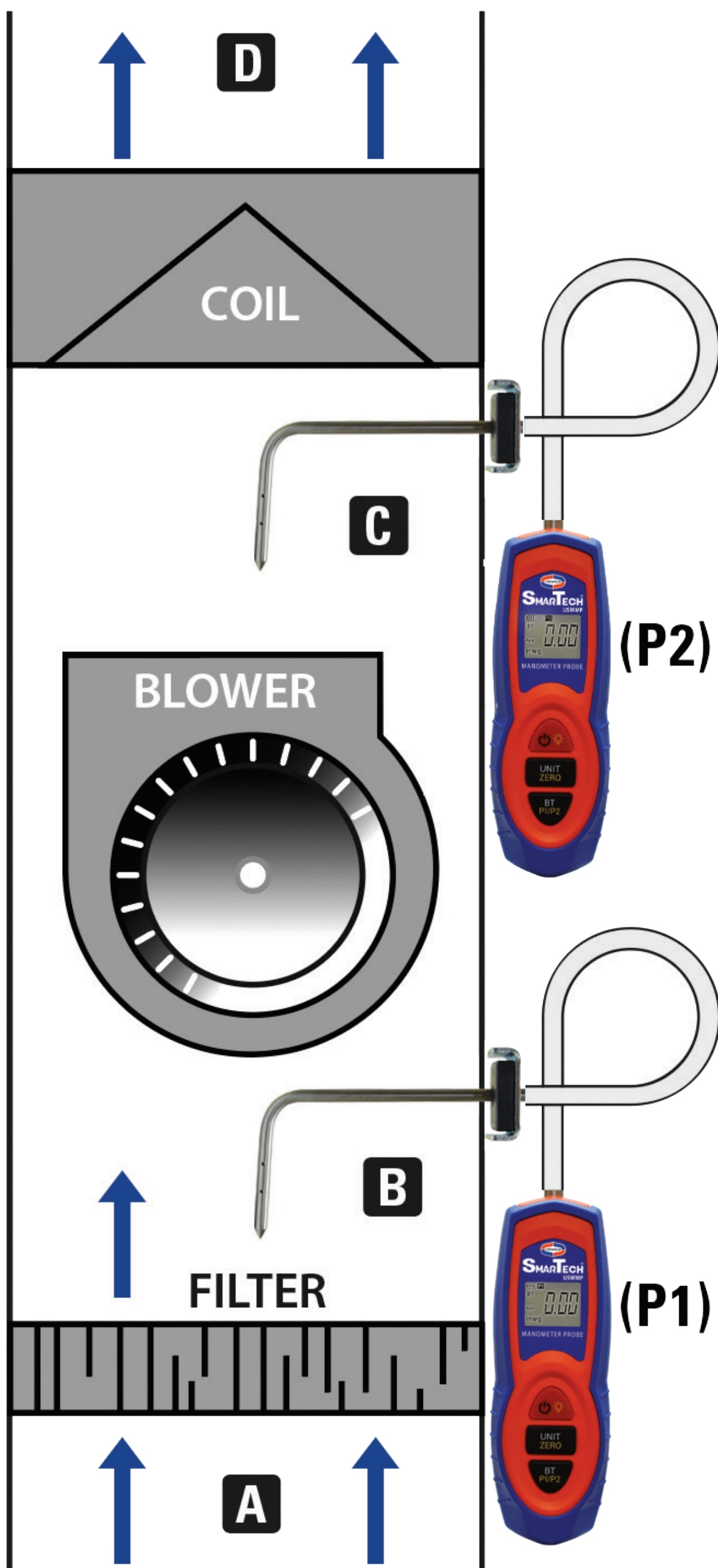

(P2) Static pressure testing ensures if the equipment is operating within factory specifications.

1. Zero your manometer while in ambient pressure with any tubing/probes attached before taking measurements. For measurements less than 2 inwg, take reading within 1 minute after zeroing for best accuracy.
2. Use the included static pressure tip when checking static pressure in an airflow stream.

**NOTE:** The red arrow on the static probes should point toward the airflow of the stream.

3. Place a SPM before and after the filter to measure your filter pressure drop (**B A**).
4. Place a SPM before and after the coil to measure your coil pressure drop (**D C**).
5. Place a SPM in the inlet and outlet air of the equipment to measure your total external static pressure (**C BA**). Check with manufacturer to determine TESP test locations.

**NOTE:** If you are in an environment where the temperature is noticeably changing while you are taking your reading, it is advised that you disconnect the probe from the tubing and ZERO it relative to the ambient air before each reading.

## 1. STEP CONNECTOR CONNECTING PROCEDURE

- Smaller end (3/16") of the step connector connects SPM tubing. Remove the installed brass fitting from tube so the step connector can be inserted.
- Step Connector
- Step Connector Tube (5/16")
- Outlet Pressure Boss

## 2. ASP1 MAGNETIC STATIC PRESSURE PROBE

For Accurate Static Pressure Measurements.

- Connect ASP1 to Manometer via hose.
- Insert ASP1 into drilled or pre-existing 1/4" hole.
- Adjust probes to face airstream.
- Read static pressure measurements from the display on the Manometer.
- Remove probe and patch hole.  
Note: For best accuracy on measurements less than 2inWC, take measurement within 1 minute of zeroing.

## 3. TF100 – TAPERED TEE

For Testing Pressure switches on live system.

- Insert Tee where inline pressure measurement is required.
- Connect Manometer to open port on TEE.

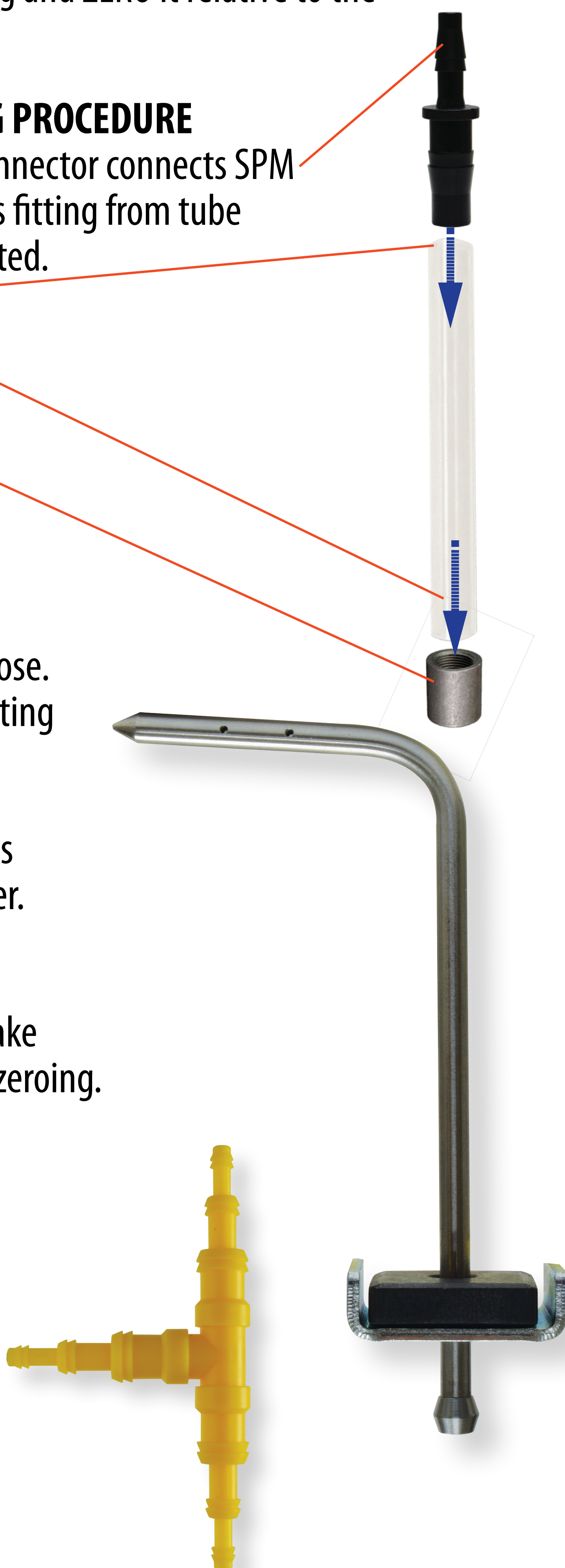

## NITROGEN PRESSURE TEST

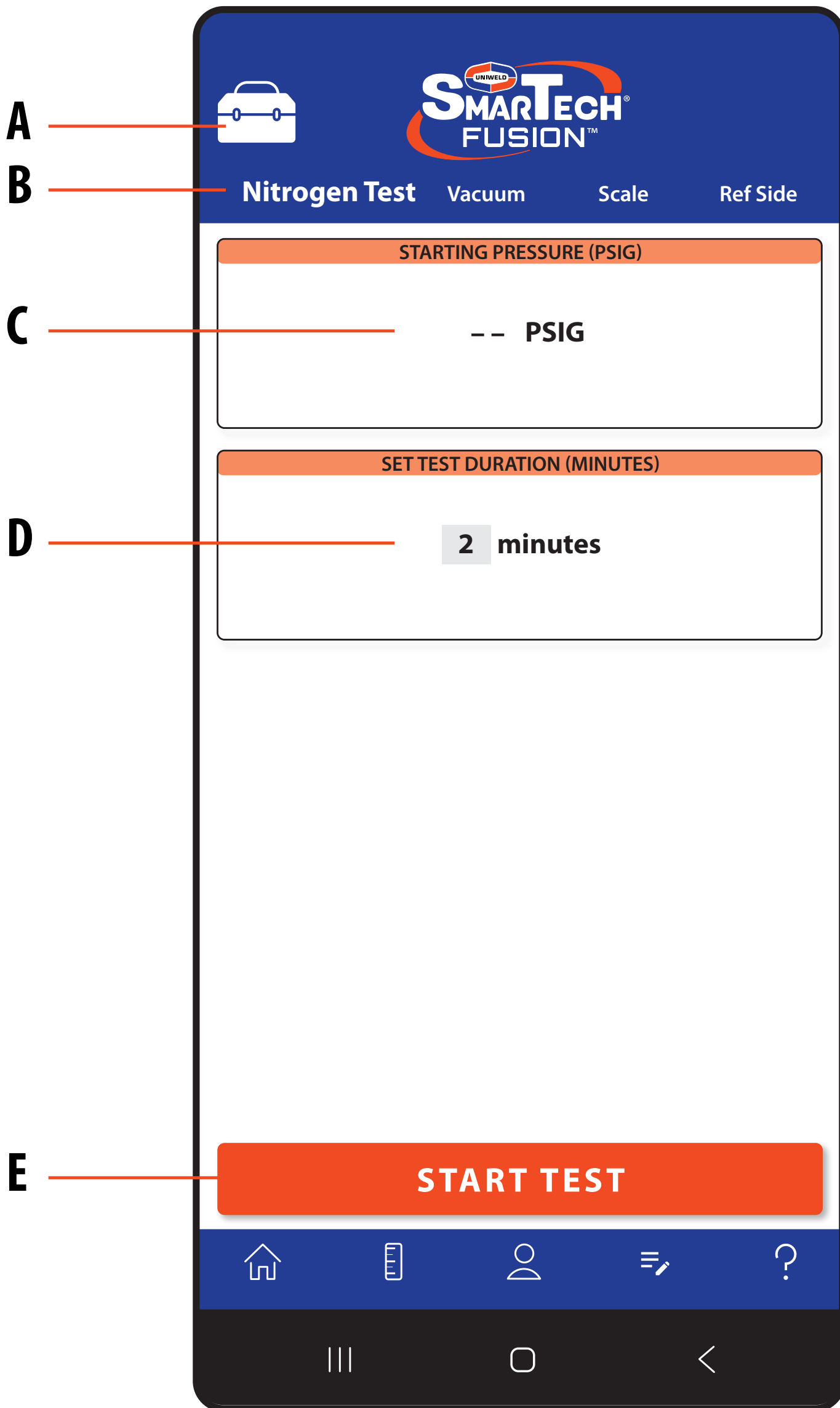

- A.** Tool Box  
clicking this will open to the tools section (page 14)
- B.** Nitrogen Test  
(tap or swipe left/right to view)
- C.** Starting/Current Pressure
- D.** Set Test Duration
- E.** Start Test
- Home
- Units Screen
- User Info
- Reporting
- Support

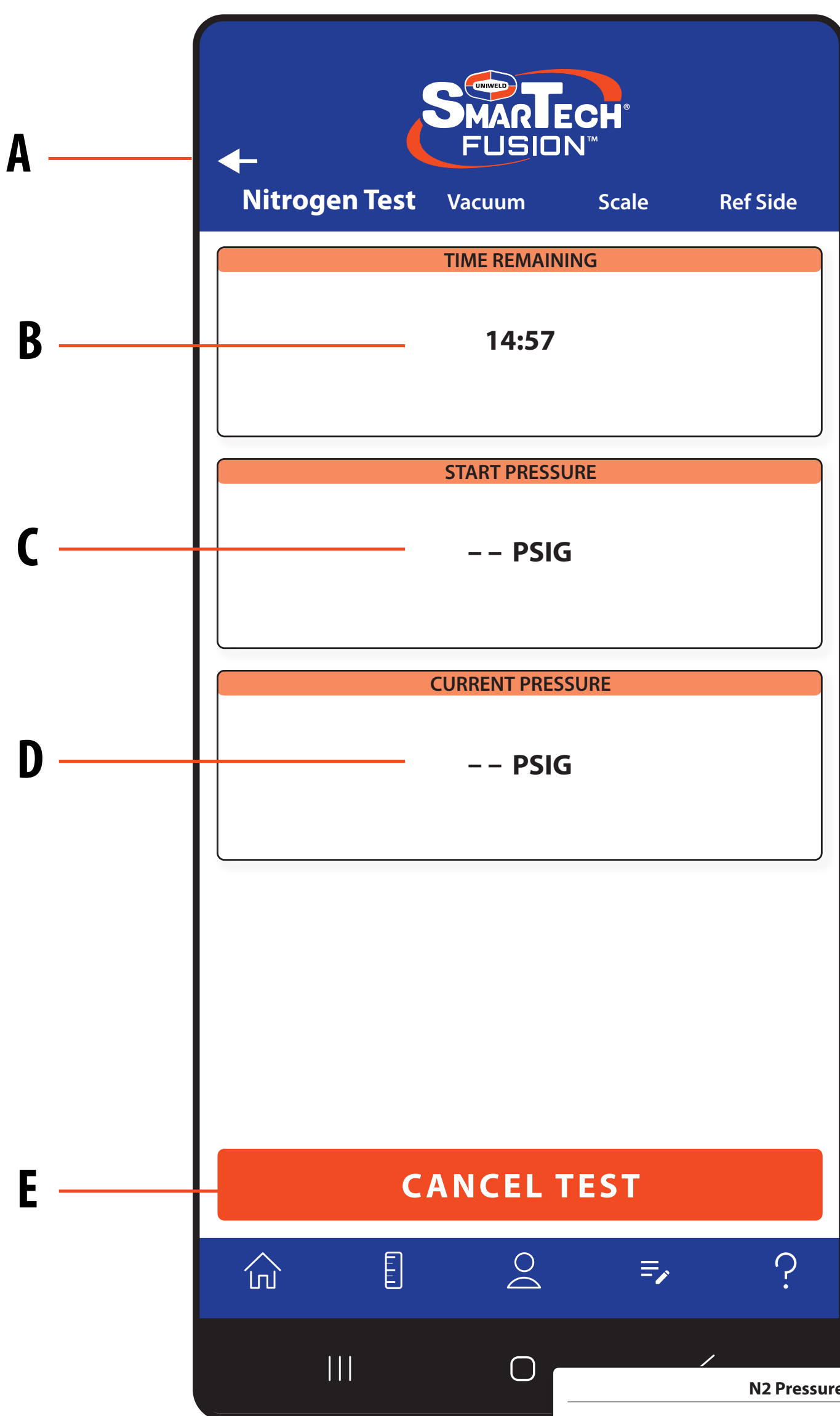

- A.** Back
  - B.** Time Remaining:  
live time reading
  - C.** Start Pressure
  - D.** Current Pressure
- Popup will show up if there is a leak or test is finished.**
- E.** Cancel Test
  - F.** Test Summary
  - G.** Pass/Fail Indication
  - H.** Test Times
  - I.** Pressure Summary
  - J.** Re-Test
  - K.** Log Data for report

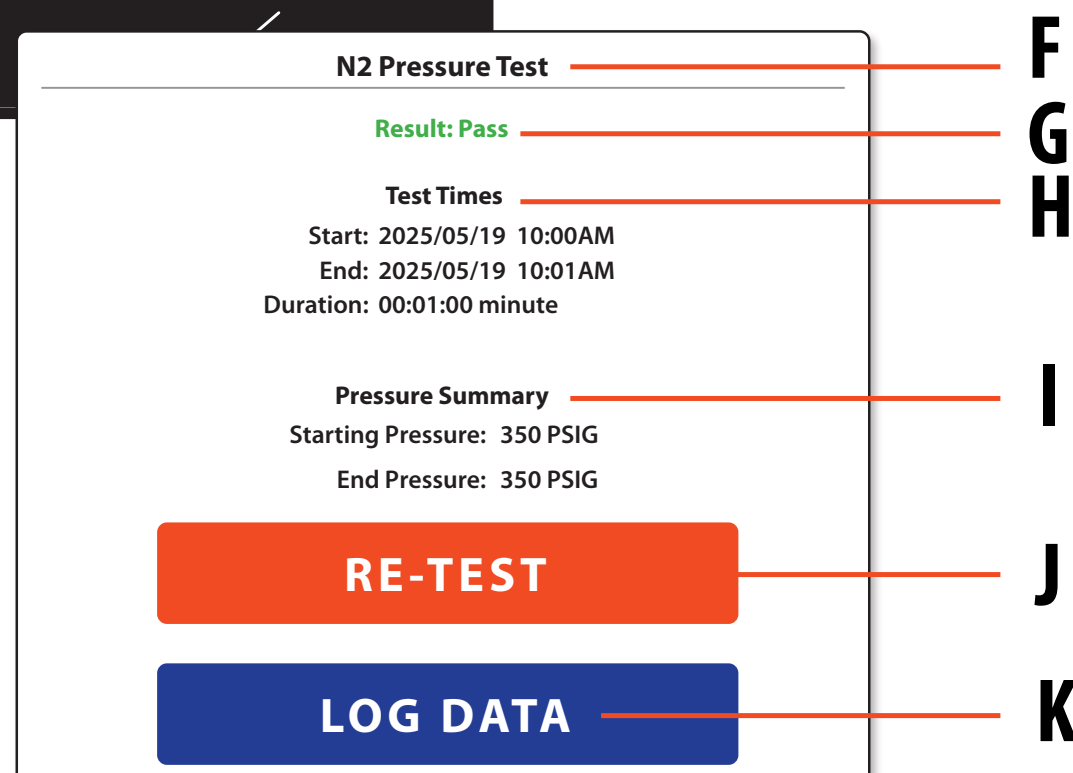

# APP OVERVIEW

## NITROGEN PRESSURE TEST TOOL CONNECTION

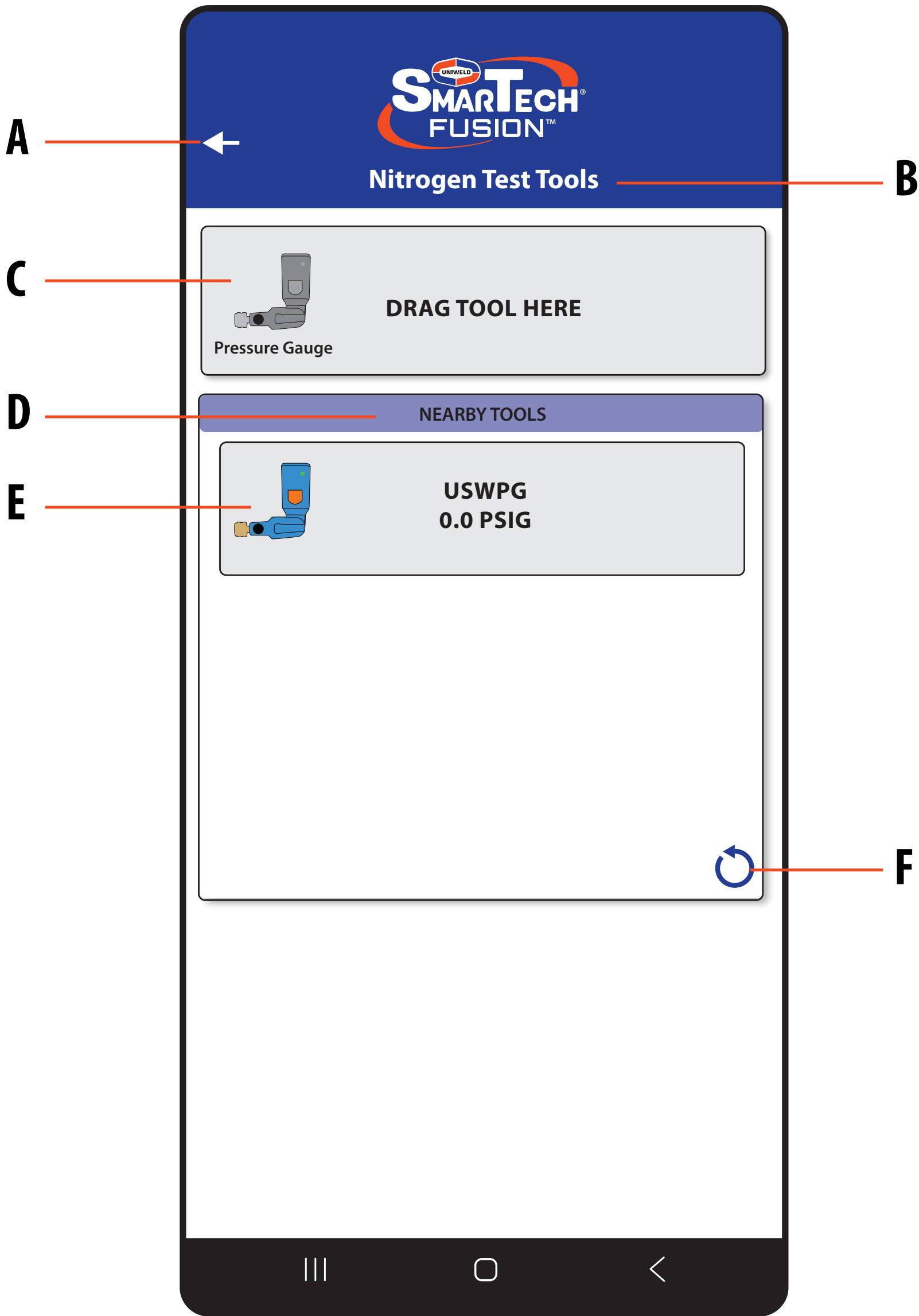

- A. Back
- B. Nitrogen Test Tools
- C. Drag tool here for connection
- D. Nearby Tools
- E. Tool found but not assigned
- F. Refresh nearby tools

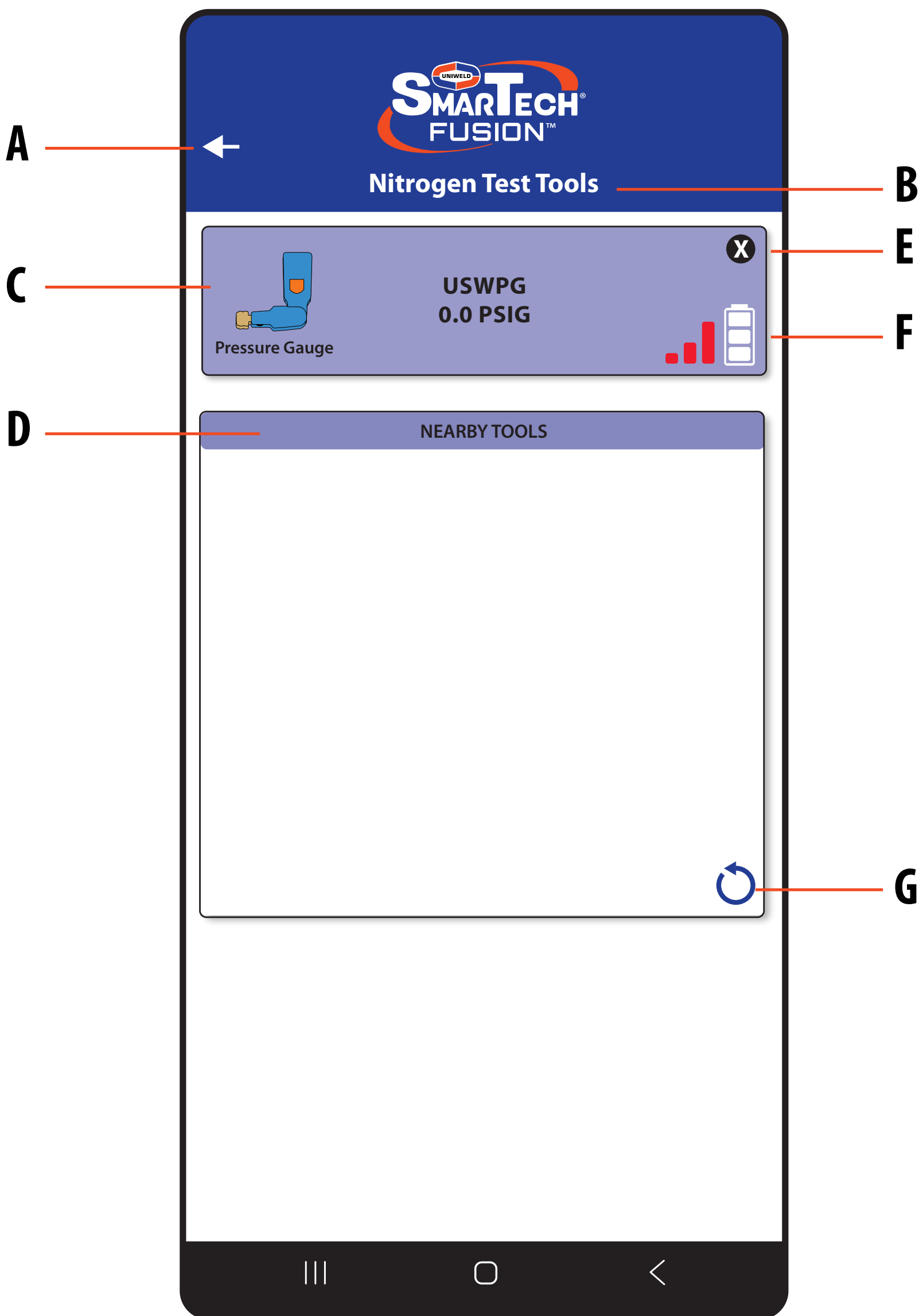

- A. Back
- B. Nitrogen Test Tools
- C. Tool assigned
- D. Nearby Tools
- E. Forget Tool
- F. Battery level and signal strength
- G. Refresh nearby tools

# APP OVERVIEW

## VACUUM TEST

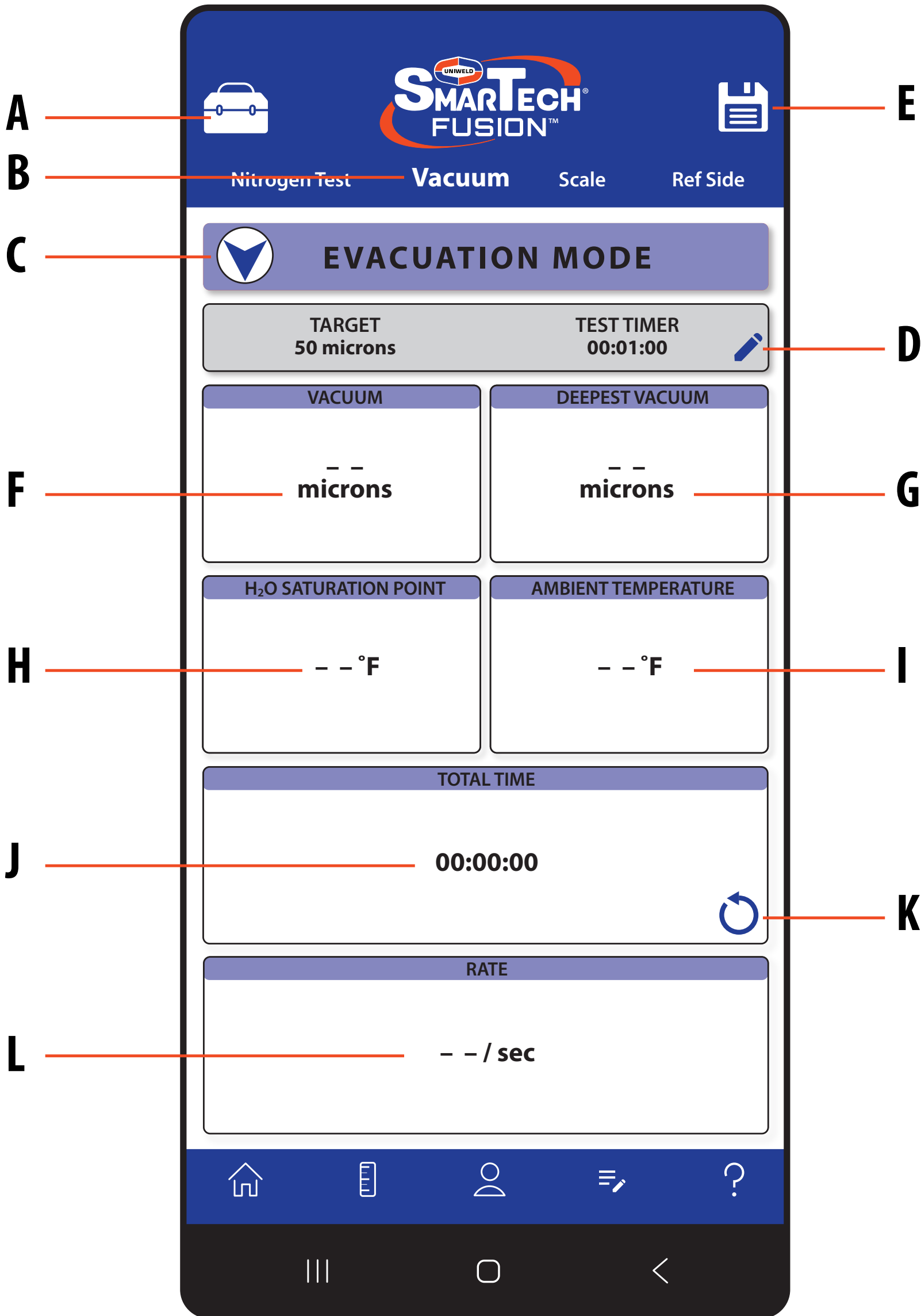

- A.** Tool Box (clicking this opens tool section page 17)
- B.** Vacuum Test (tap or swipe to view)
- C.** Toggle Button (Evacuation Mode)
- D.** Test Parameters (clicking this icon opens illustration A pop-up on page 16)
- E.** Save Results for Report
- F.** Live Vacuum Reading
- G.** Deepest Vacuum
- H.** H<sub>2</sub>O Saturation Point
- I.** Ambient Temperature
- J.** Timer
- K.** Restart Timer
- L.** Evacuation Rate

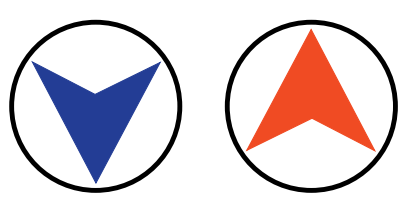

**Toggle Button:** tapping this will toggle between Evacuation mode and Rise Test mode.

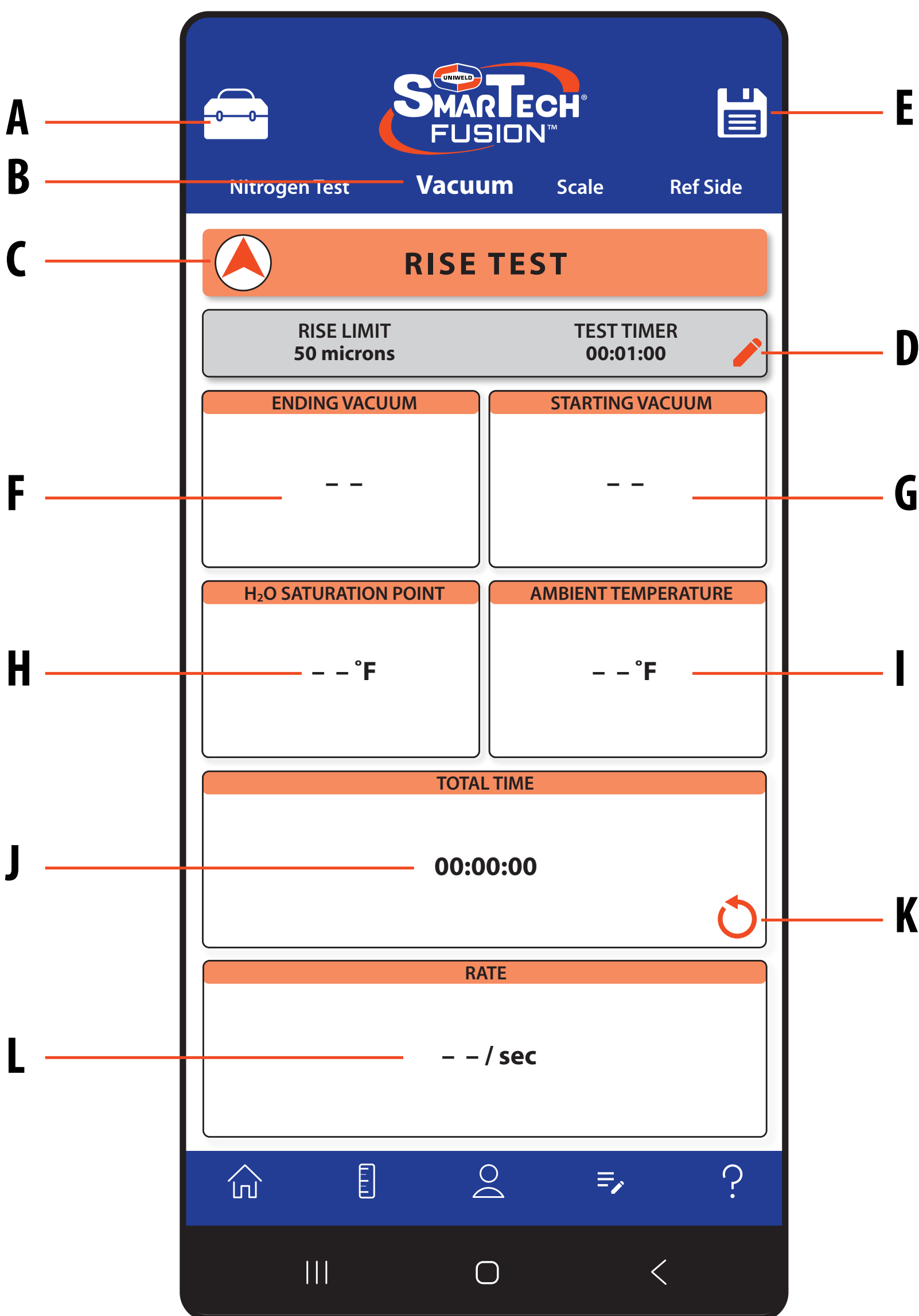

- A.** Tool Box (clicking this opens tool section page 17)
- B.** Vacuum Test (tap or swipe to view)
- C.** Toggle Button (Rise Test)
- D.** Test Parameters (clicking this icon opens illustration B pop-up on page 16)
- E.** Save Results for Report
- F.** Live/Ending Vacuum Reading
- G.** Starting Vacuum
- H.** H<sub>2</sub>O Saturation Point
- I.** Ambient Temperature
- J.** Timer
- K.** Restart Timer
- L.** Rise Rate

# APP OVERVIEW

## VACUUM TEST

Illustration A

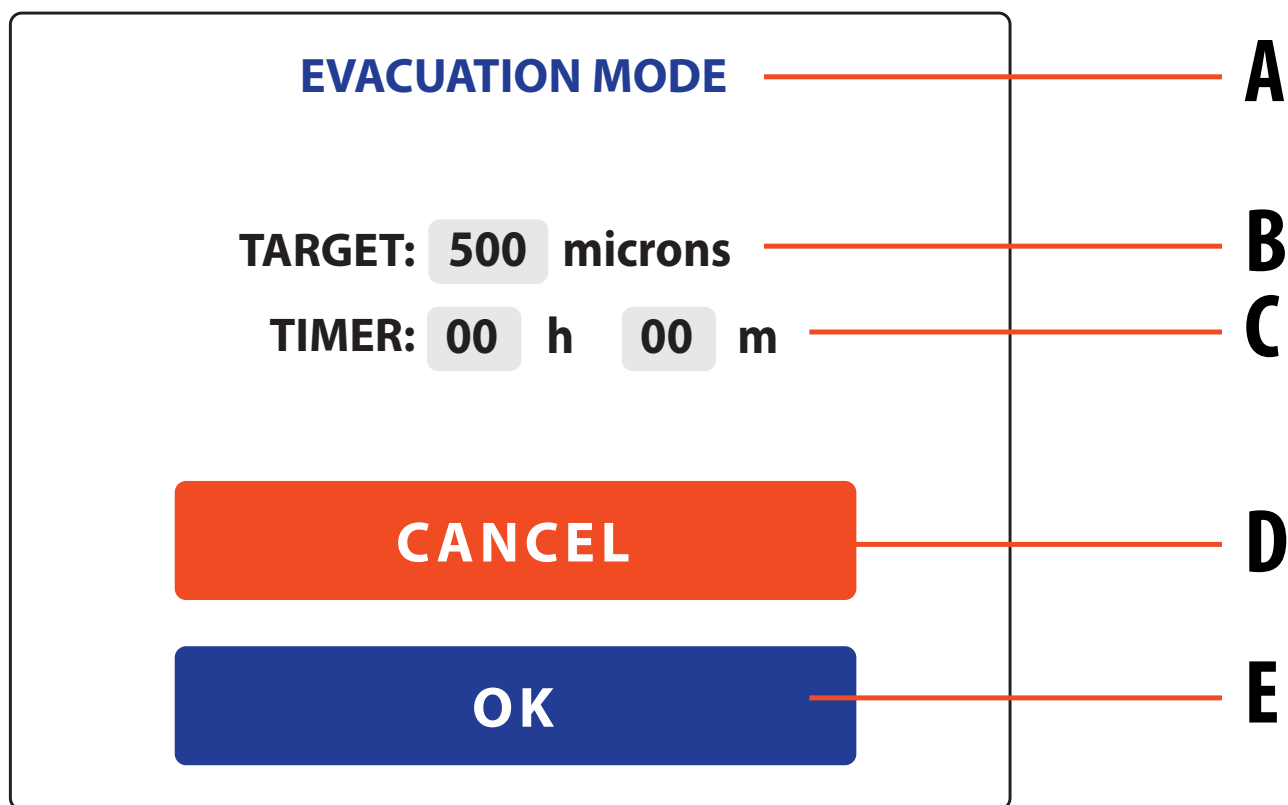

- A. Evacuation Mode Parameters
- B. Evacuation Target (Default 500 microns)
- C. Test Timer
- D. Cancel
- E. OK

Illustration B

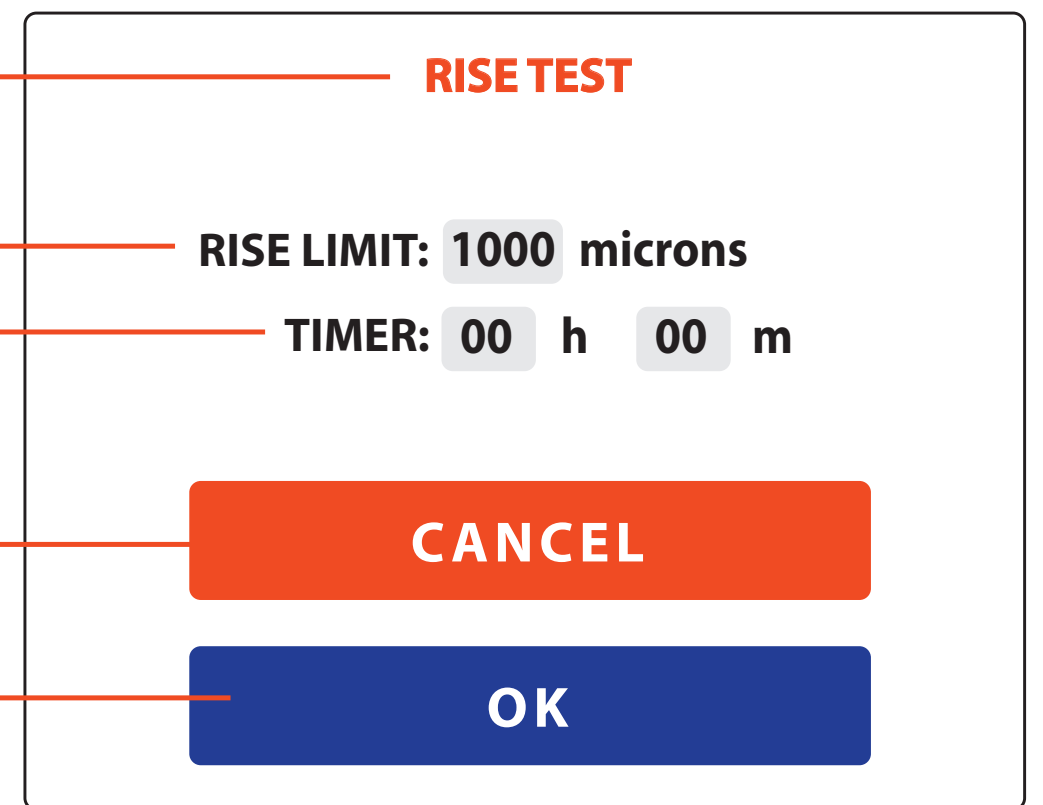

- F. Rise Test Parameters
- G. Rise Limit (Default 1000 microns)
- H. Test Timer
- I. Cancel
- J. OK

**Grey Box:** Indicates a typeable/editable field

Illustration C

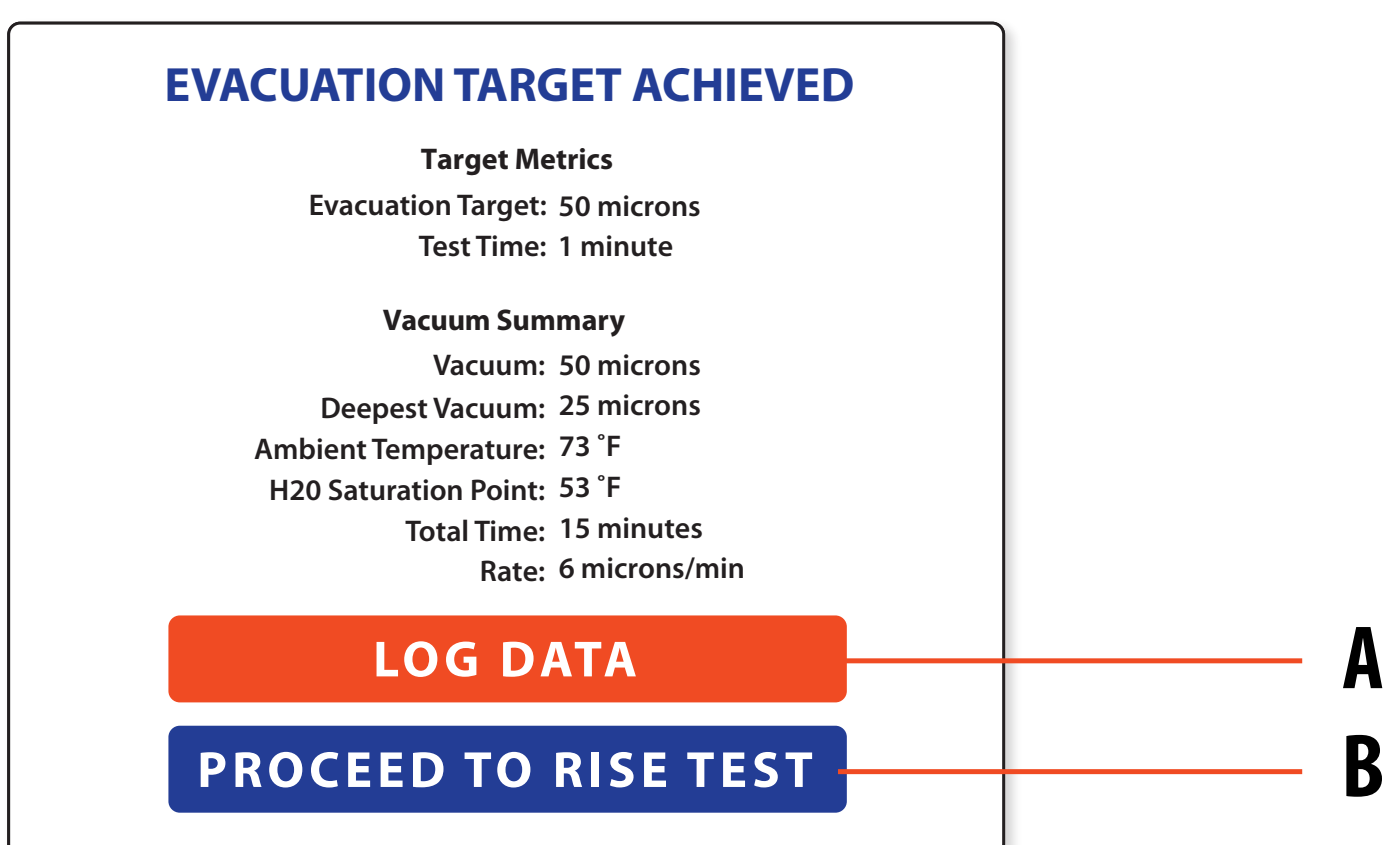
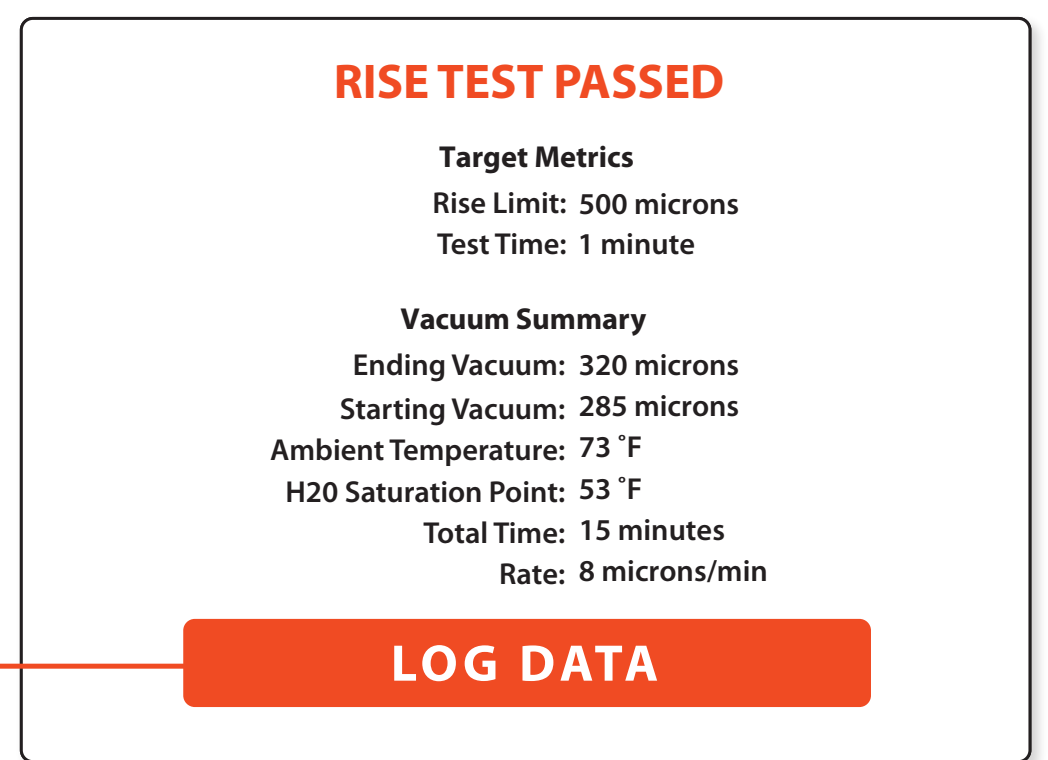

Illustration D



After a successful Evacuation Test, illustration C pop-up appears with the test results.

After a successful Rise Test, illustration D pop-up appears with results.

- A. Log Data for Report
- B. Proceed to Rise Test (illustration E pop-up)

Illustration E

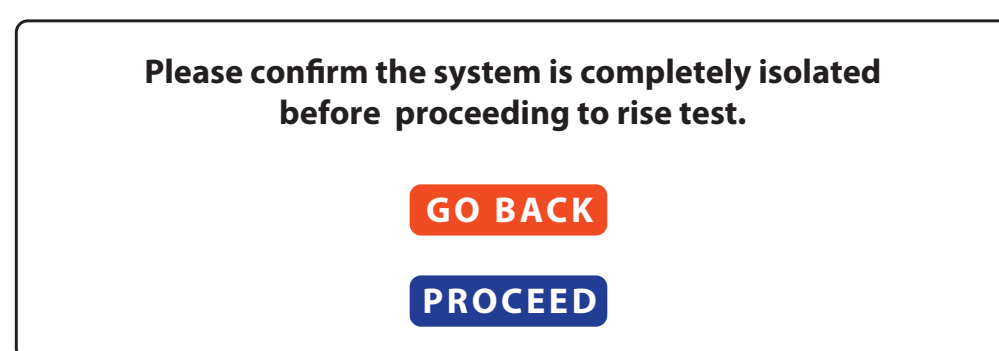

Illustration F

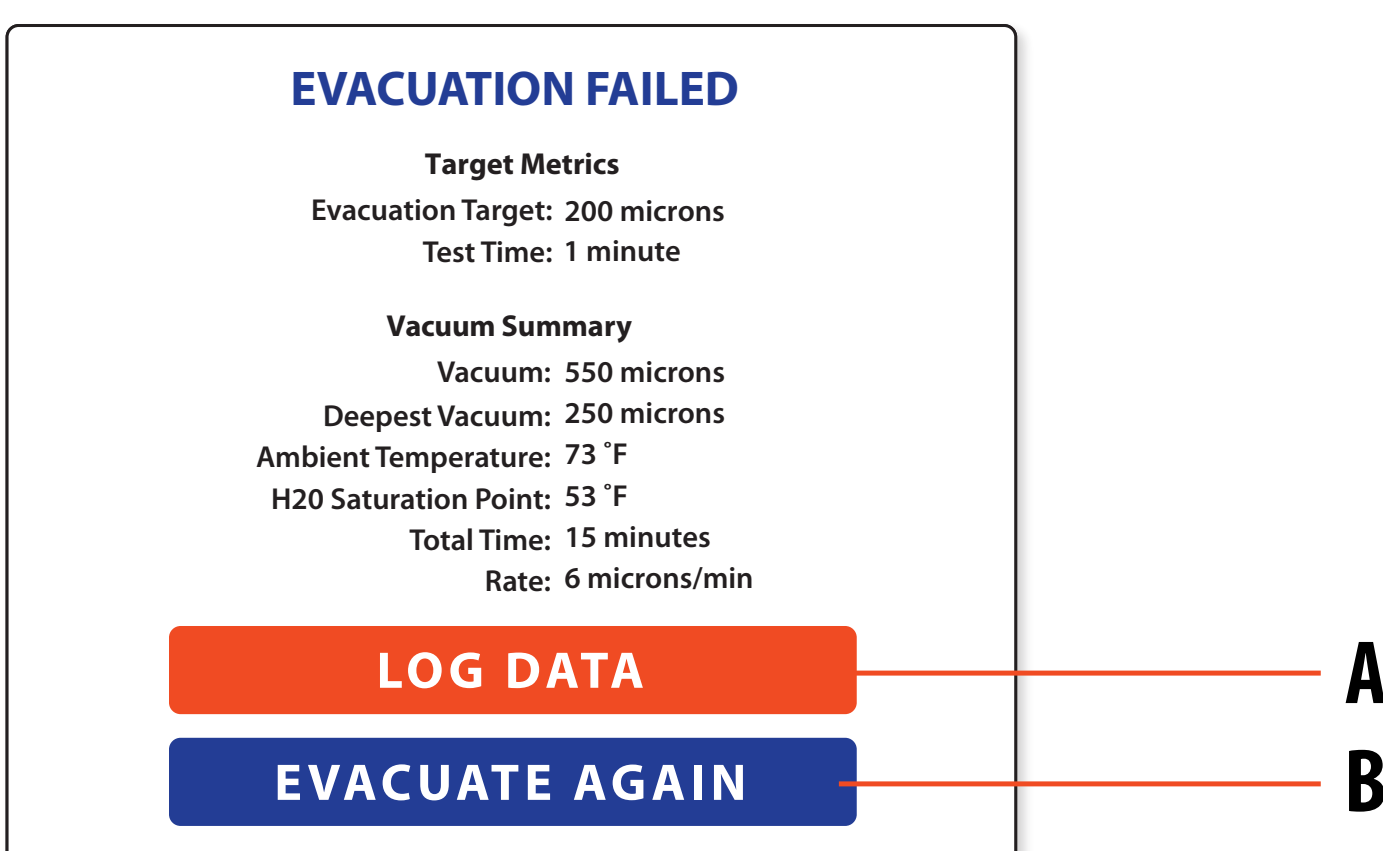

Illustration G

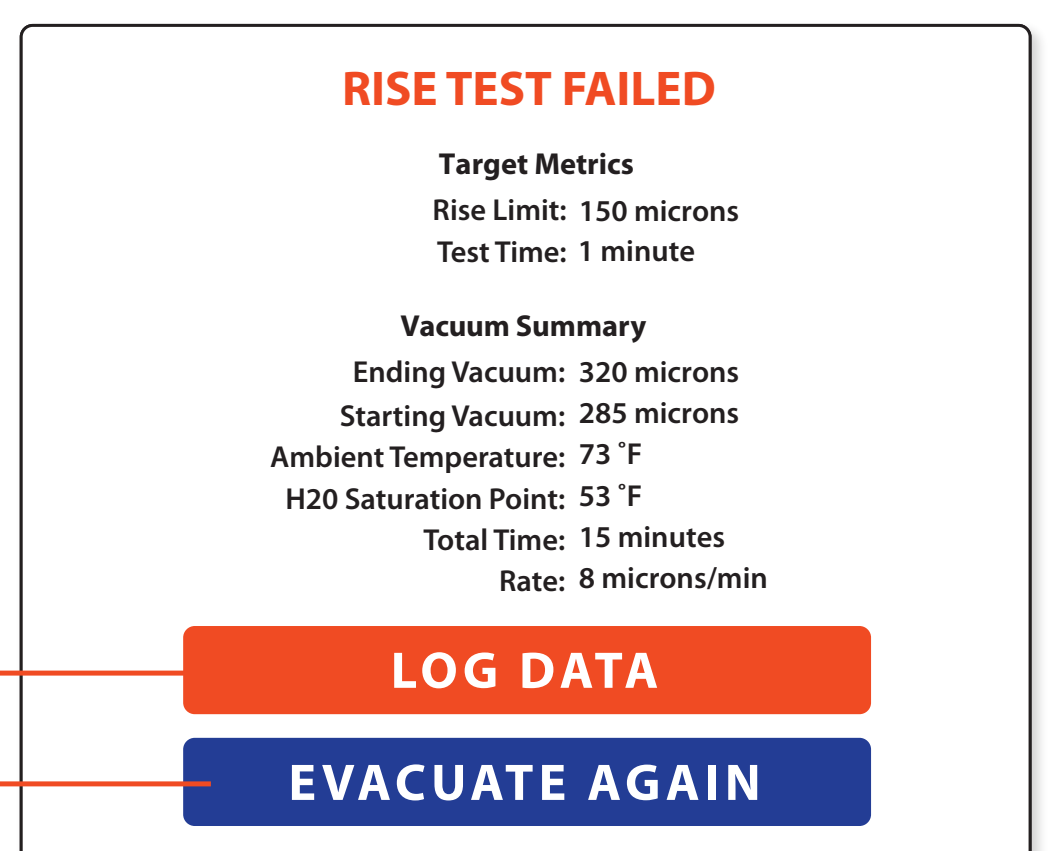

Illustration E pop-up reminds user for isolation check prior to Rise Test.

Illustration F & G pop-ups indicate a Failed Evacuation/Rise Test scenario with the Test Results.

- A. Log Data for Report
- B. Evacuate Again

# APP OVERVIEW

## VACUUM TEST TOOL CONNECTION

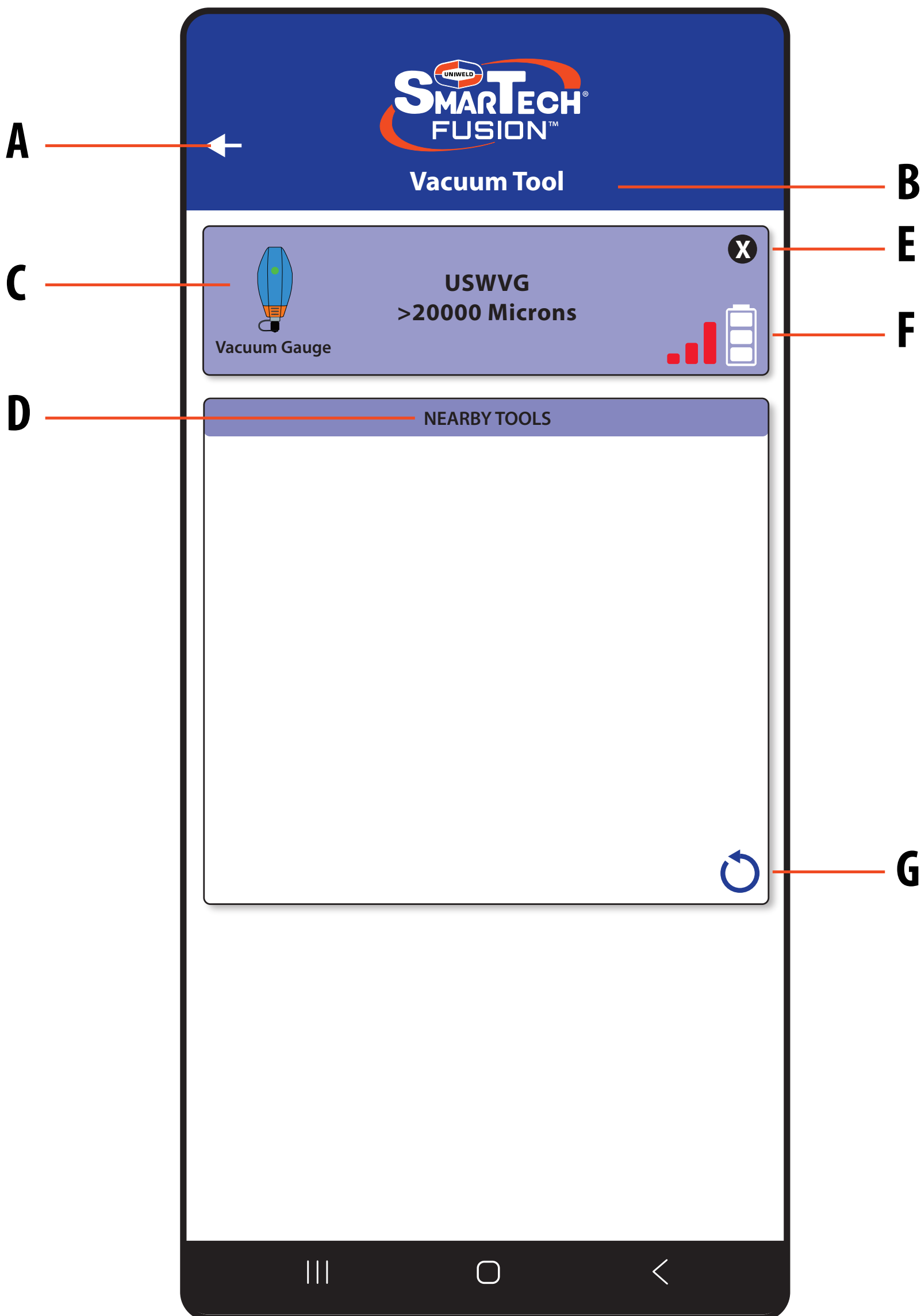
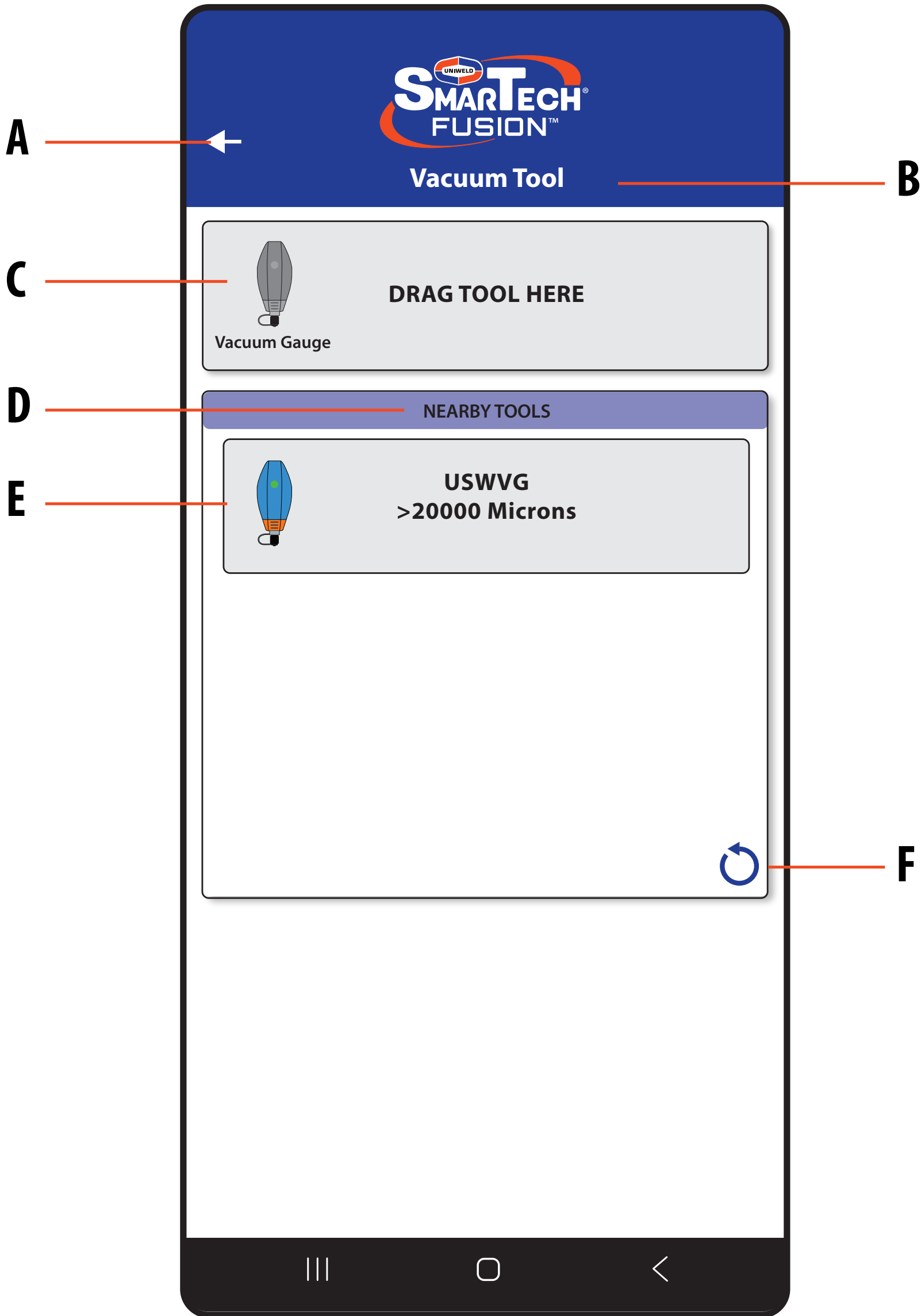

# APP OVERVIEW

## WIRELESS SCALE

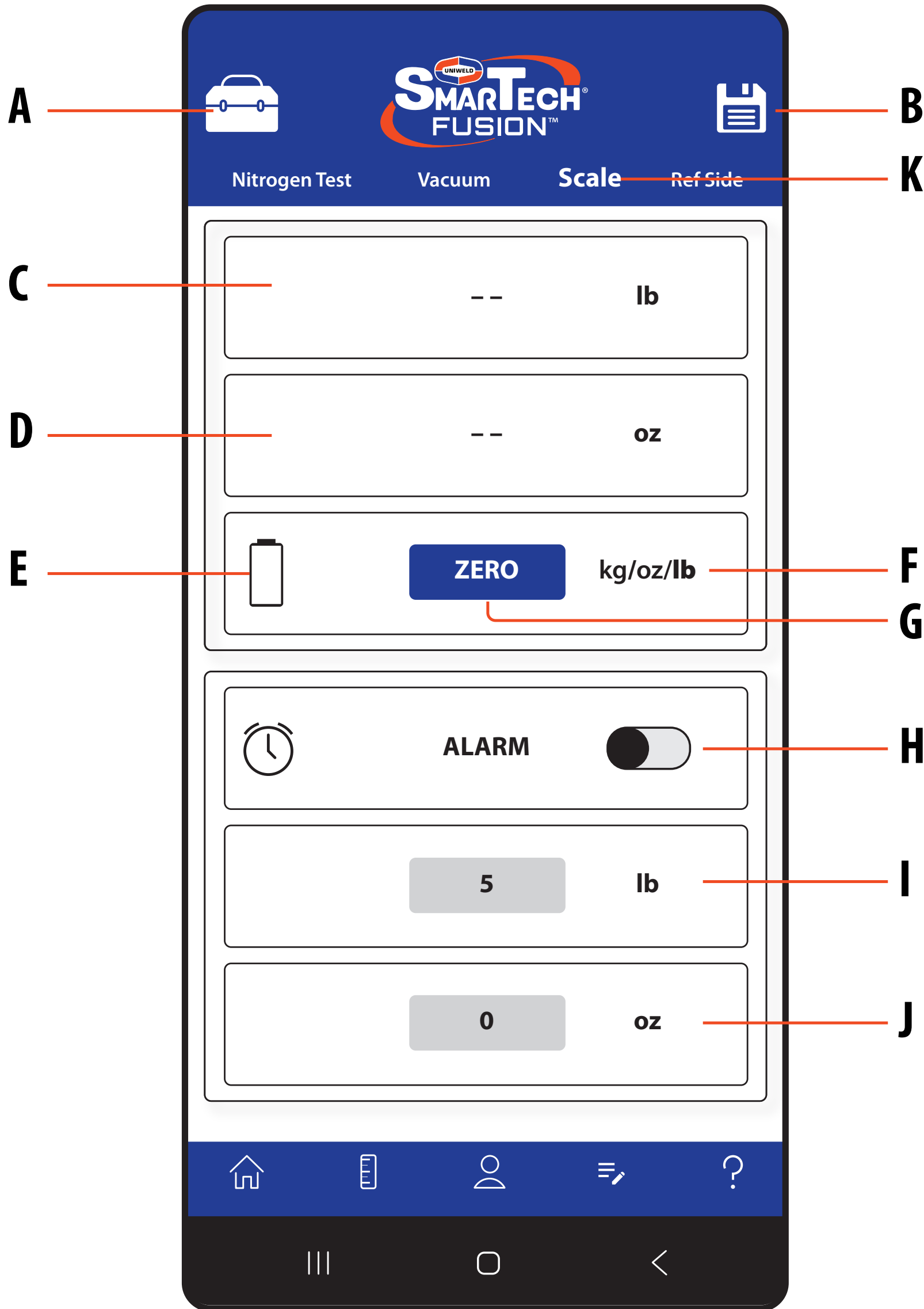

- A.** Tool Box
- B.** Save Results (opens pop-up shown below)
- C.** Measured weight (lb.)
- D.** Measured weight (oz.)
- E.** Battery indication
- F.** Zero (Tare weight)
- G.** Switch measured units
- H.** Toggle switch to activate the alarm
- I.** Preset weight (lb.)
- J.** Preset weight (oz.)
- K.** Scale (tap or swipe to view)

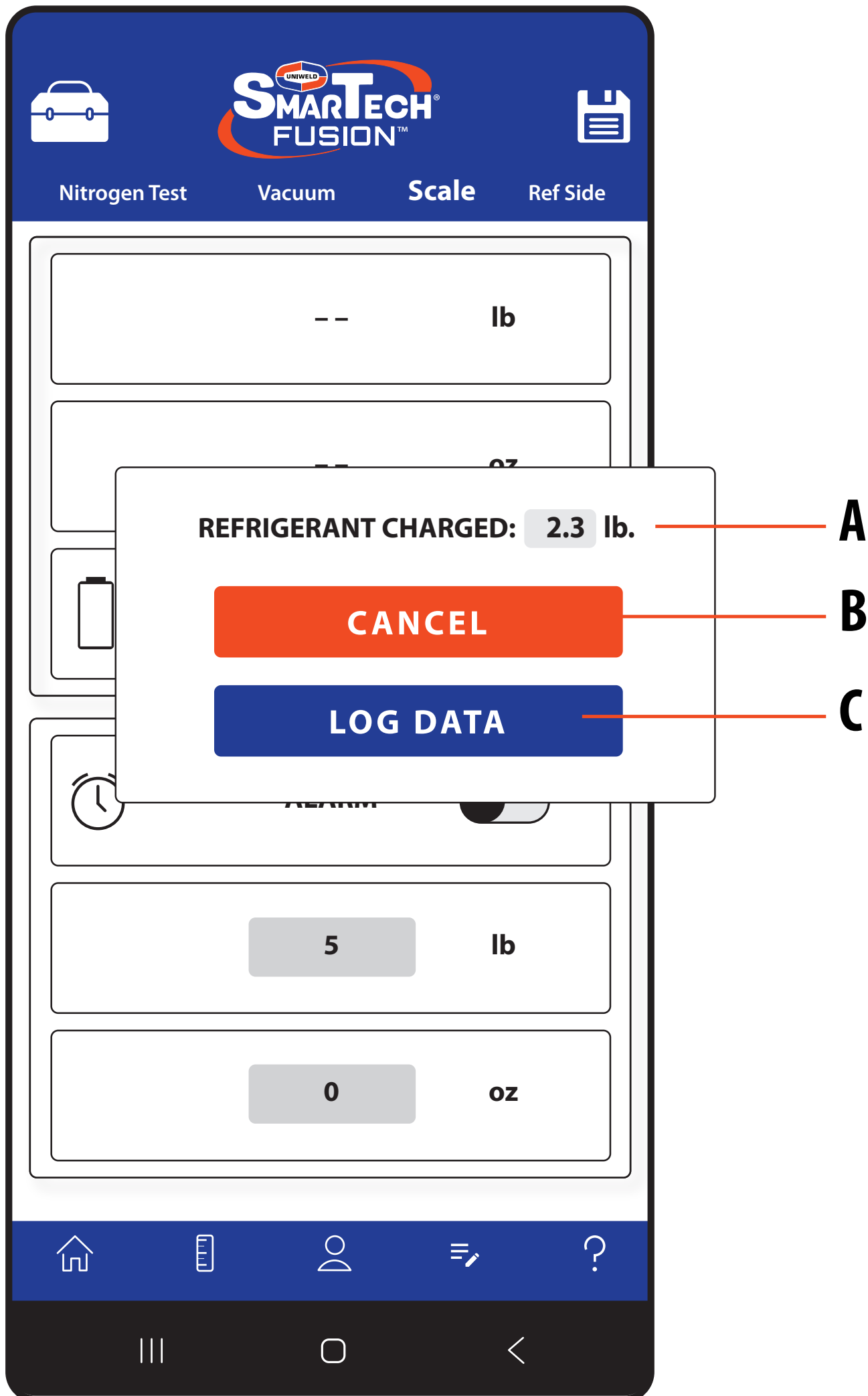

- A.** Refrigerant charged
- B.** Cancel
- C.** Log Data (Logs the refrigerant charge value to the project notes section of the report with a time stamp)

## WIRELESS SCALE TOOL CONNECTION

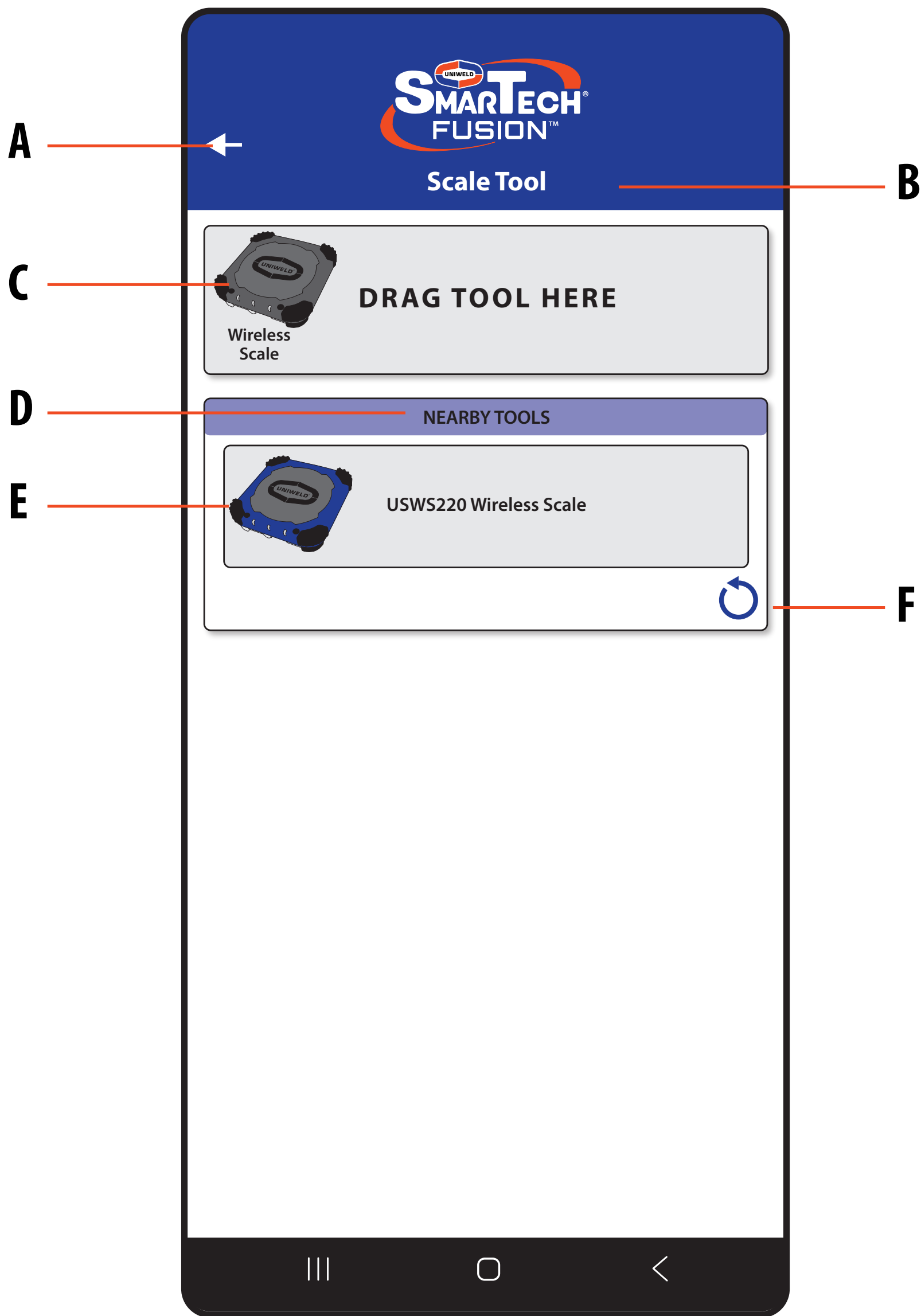

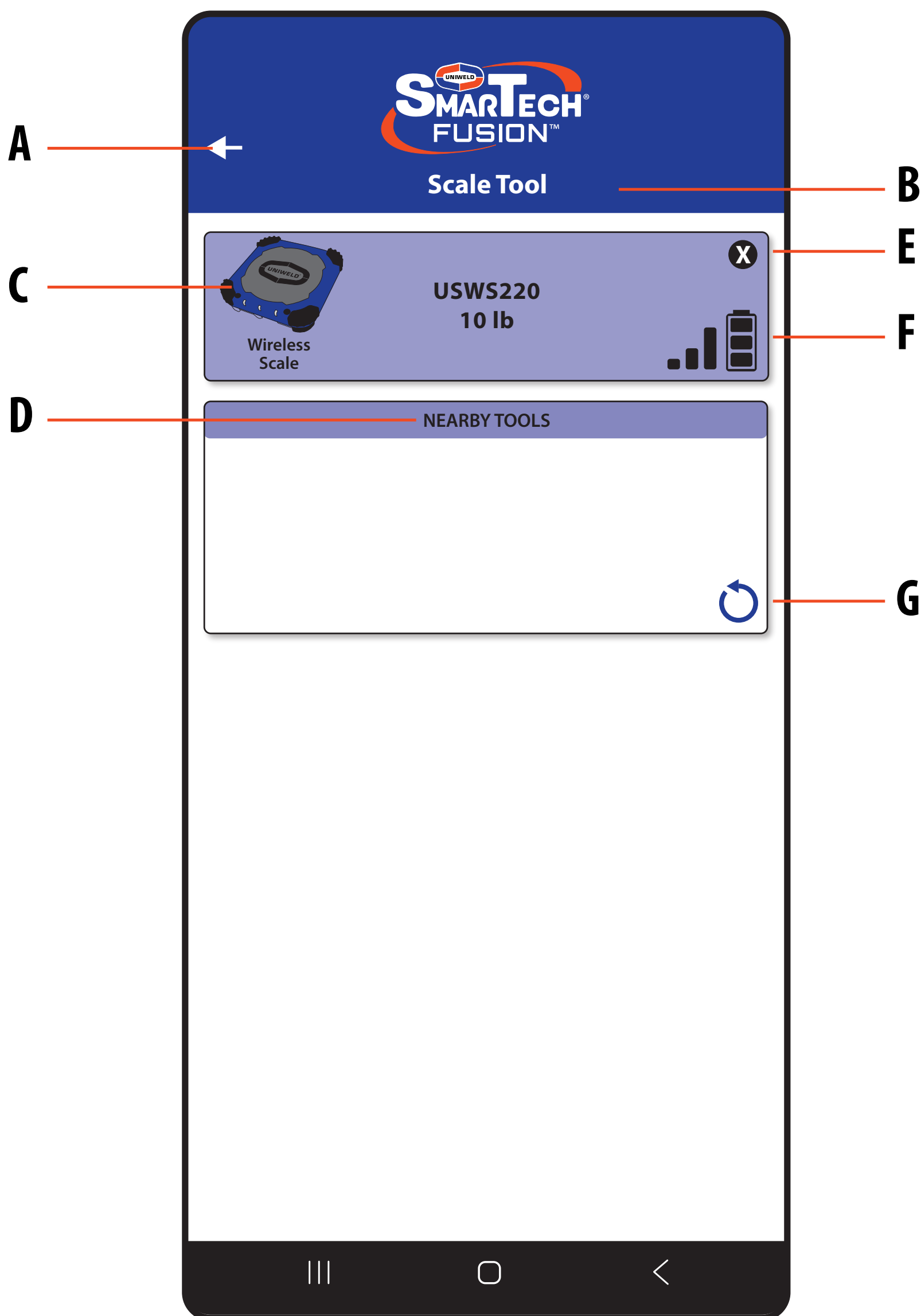

- A. Back
- B. Scale Tool
- C. Drag tool here for connection
- D. Nearby Tools
- E. Tool found but not assigned (
- F. Refresh nearby tools



- A. Back
- B. Scale Tool
- C. Tool assigned
- D. Nearby Tools
- E. Forget Tool
- F. Battery level and signal strength
- G. Refresh nearby tools

Note: to activate bluetooth communication on the scale. Press and hold  on the scale remote for 5 seconds to activate Bluetooth pairing.

- The Bluetooth icon  will appear on the display when pairing.
- Once paired successfully with the FUSION app, the connected icon  will appear.
- Bluetooth pairing is off by default each time the scale powers on.

# APP OVERVIEW

## REFRIGERATION SIDE PERFORMANCE

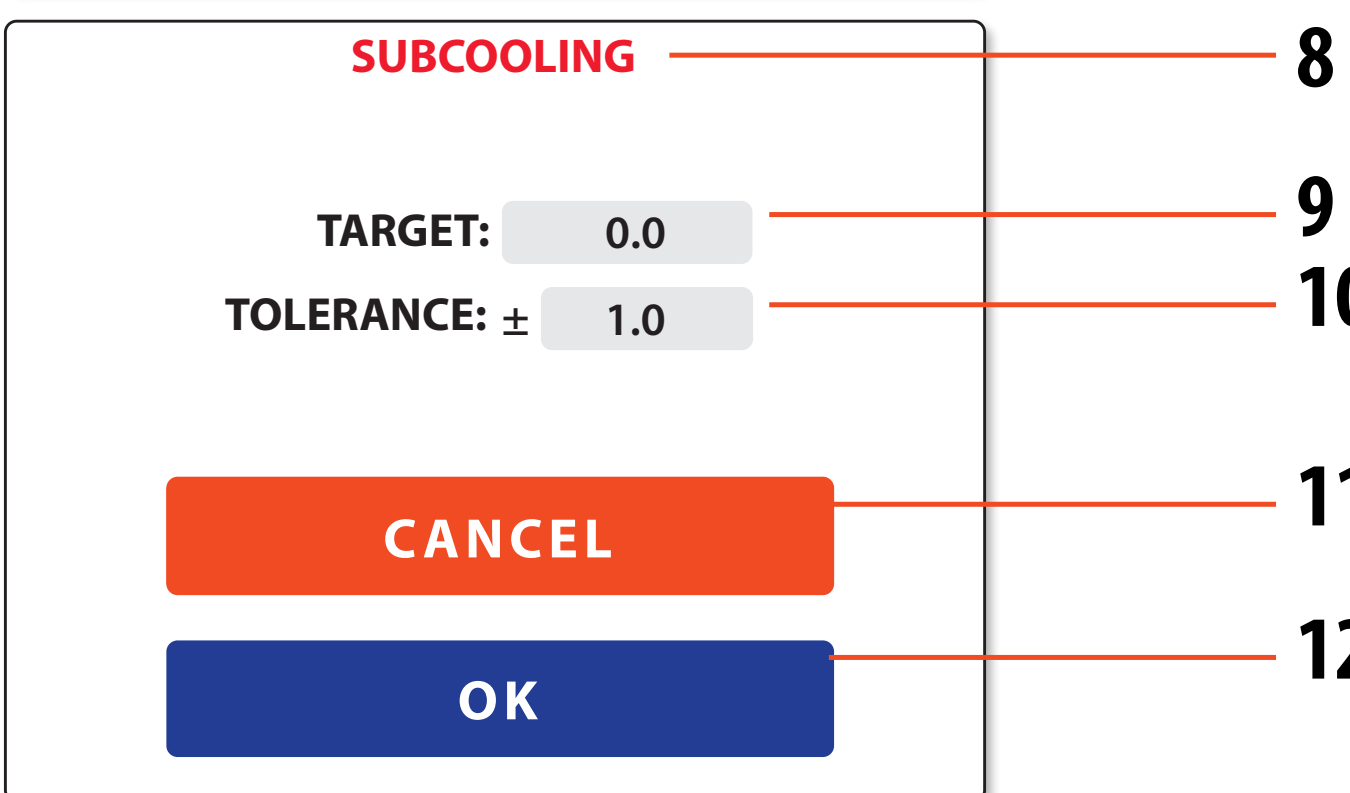
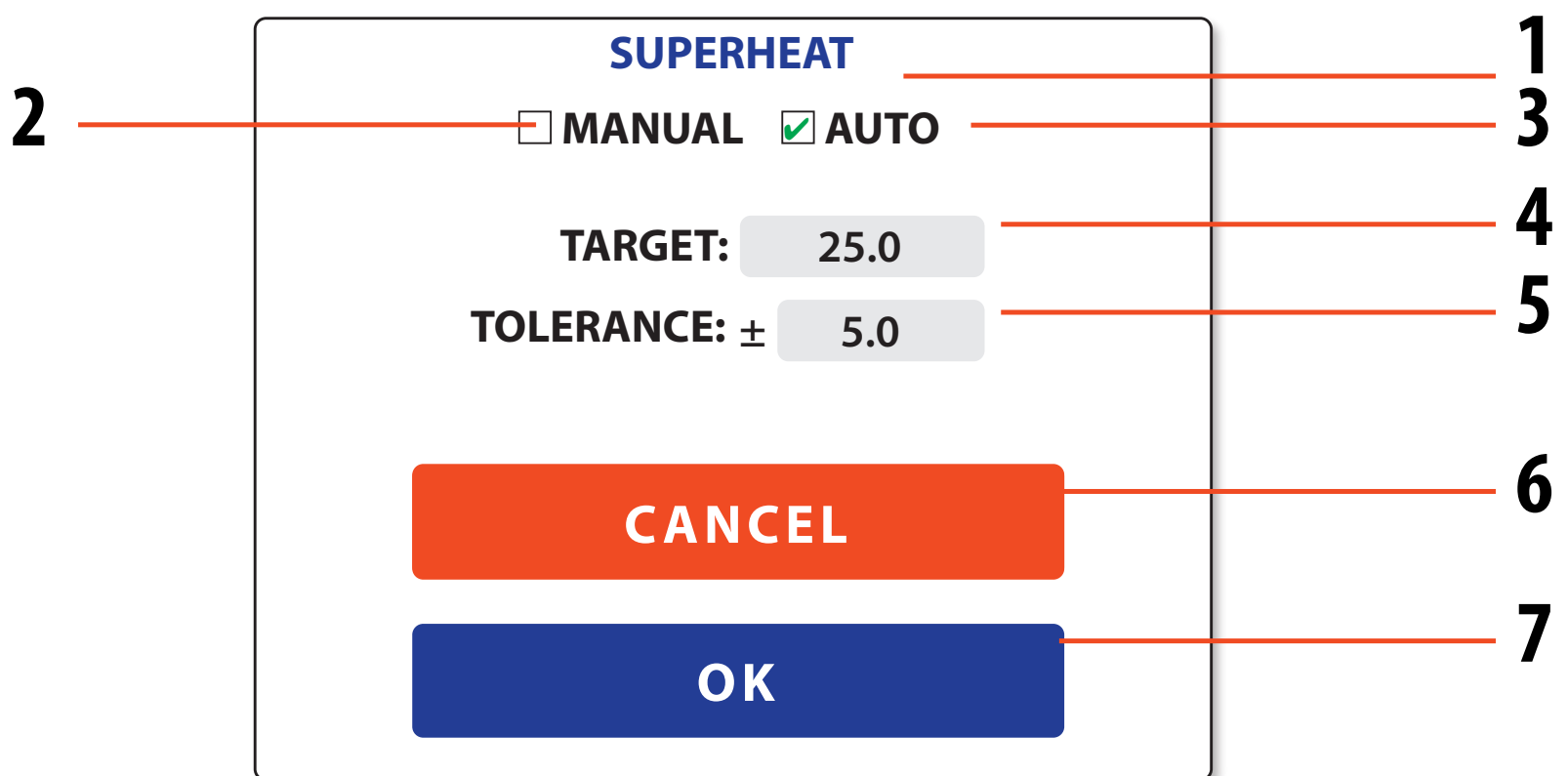
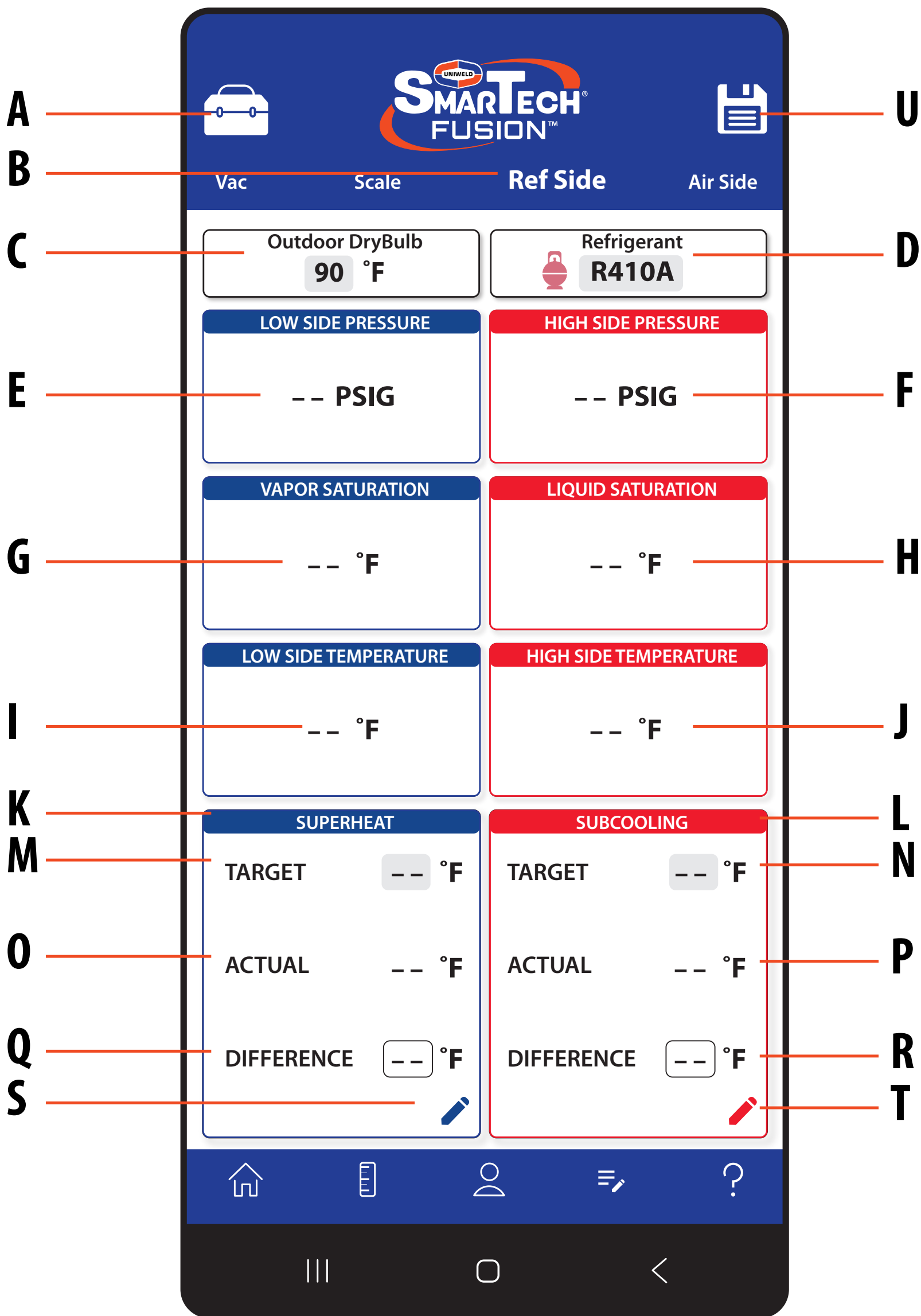

### SMART CHARGE ZONE®

Color Coded Differential for Accurate "In the Zone" System Charge.

Zone	Subcooling Target (°F)	Subcooling Actual (°F)	Subcooling Difference (°F)	Description
RED ZONE	10.0	14.6	4.6	System is over charged with refrigerant and requires removal of excess refrigerant
GREEN ZONE	10.0	10.3	0.3	System is properly charged for maximum efficiency and optimal performance
BLUE ZONE	10.0	4.2	5.8	System is under charged and requires additional refrigerant

- A. Tool Box
- B. Refrigeration Side (tap or swipe to view)
- C. Outdoor DryBulb
- D. Refrigerant in use (clicking this will allow you to select another refrigerant page 22)
- E. Low Side Pressure
- F. High Side Pressure
- G. Vapor Saturation Temp.
- H. Liquid Saturation Temp.
- I. Low Side Temperature
- J. High Side Temperature
- K. Superheat
- L. Subcooling
- M. Target Superheat
- N. Target Subcooling
- O. Actual Superheat
- P. Actual Subcooling
- Q. Superheat Difference
- R. Subcooling Difference
- S. Superheat Tolerance (clicking this will open the popup - see below)
- 1. Superheat popup
- 2. Manual entry
- 3. Auto calculation
- 4. Target (Default 25.0)
- 5. Tolerance (Default ±5.0)
- 6. Cancel
- 7. OK
- T. Subcooling Tolerance (clicking this will open the popup - see below)
- 8. Subcool popup
- 9. Target (Default 0.0)
- 10. Tolerance (Default ±1.0)
- 11. Cancel
- 12. OK
- U. Save Results for Report

# APP OVERVIEW

## REFRIGERATION SIDE TOOL CONNECTION

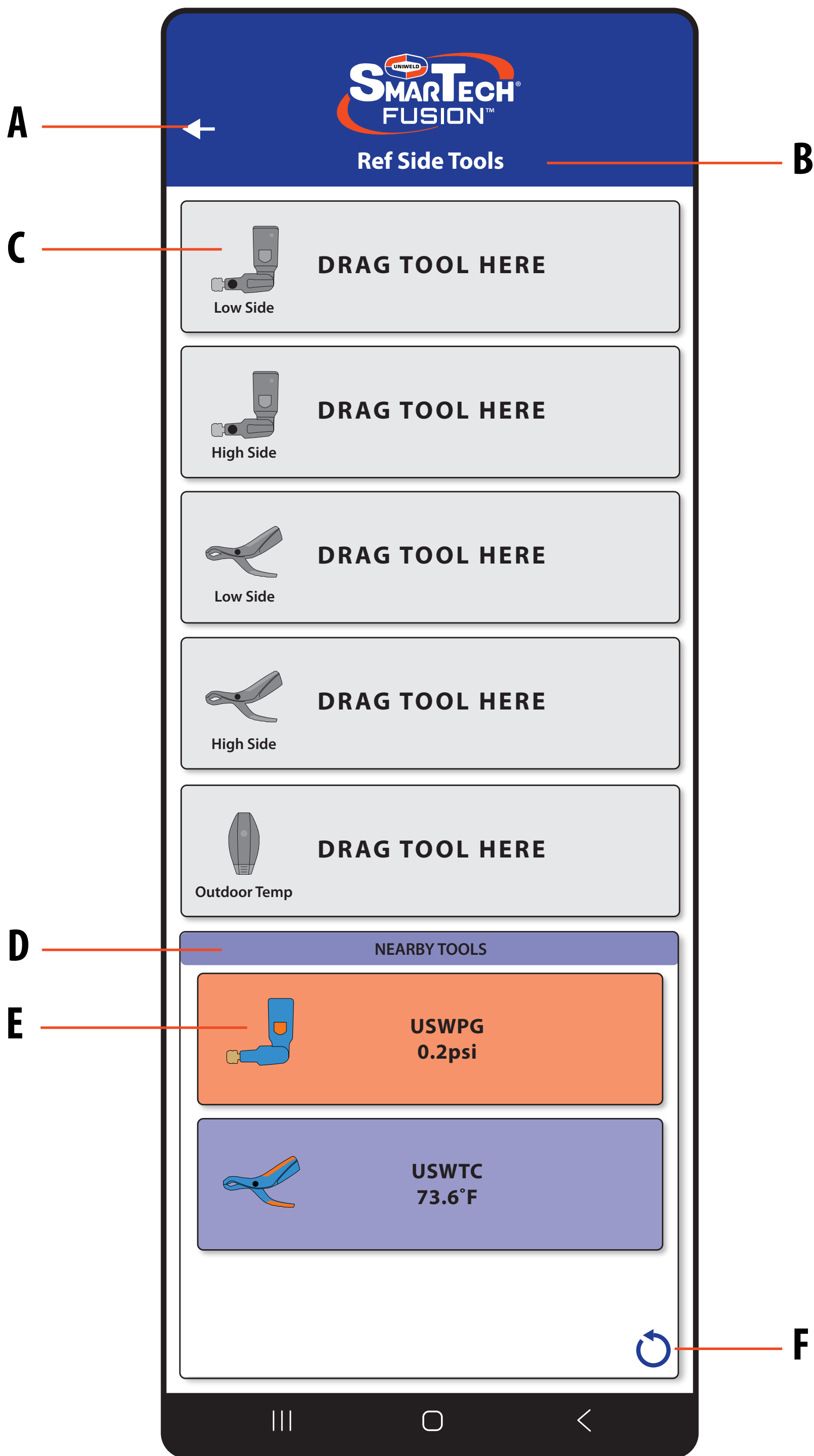

- A. Back
- B. Ref Side Tools
- C. Drag tool here for connection
- D. Nearby Tools
- E. Tool found but not assigned
- F. Refresh nearby tools

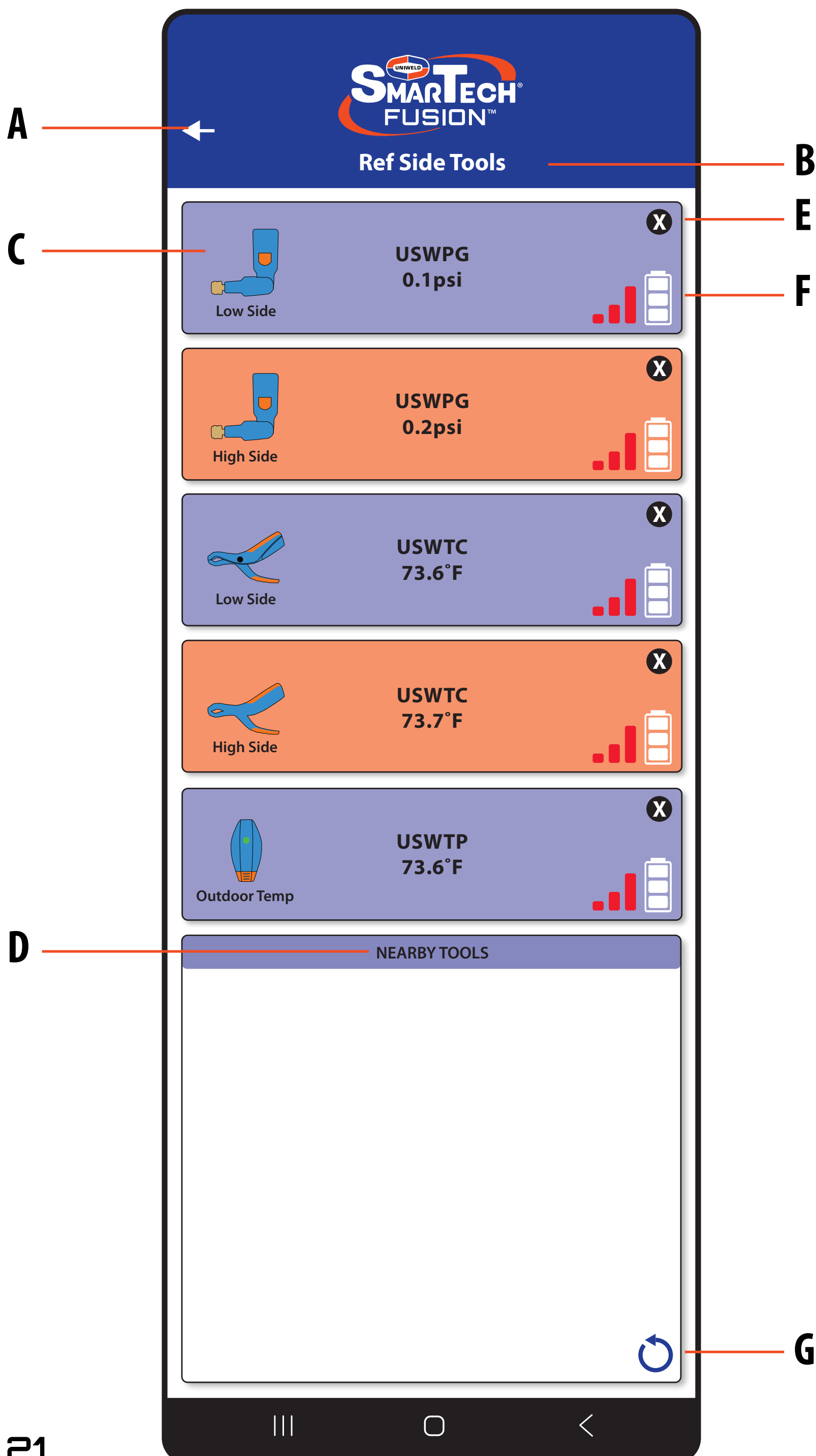

- A. Back
- B. Ref Side Tools
- C. Tool assigned
- D. Nearby Tools
- E. Forget Tool
- F. Battery level and signal strength
- G. Refresh nearby tools

## CHOOSING A REFRIGERANT

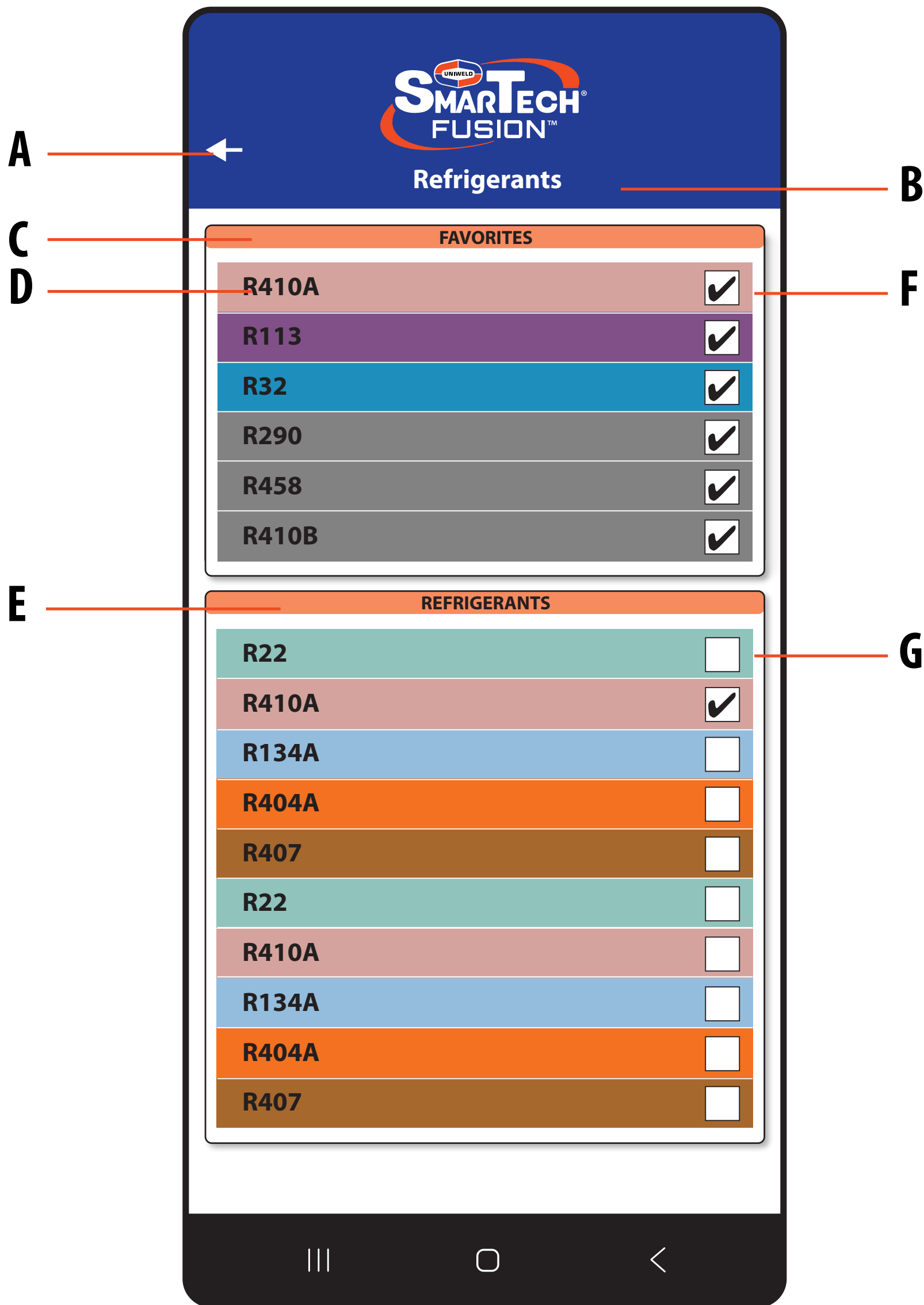

- A. Back
- B. Refrigerants
- C. List of Favorites
- D. Color Coded Refrigerants
- E. List of all Refrigerants
- F. Active Check Box
- G. Non-Active Check Box

**Activating the check box from the list of refrigerants will bring the refrigerant to the list of favorites**

R11	R402A	R418A	R448A
R113	R402B	R419A	R449A
R114	R403A	R420A	R450A
R115	R403B	R421A	R452A
R116	R404A	R421B	R452B
R12	R405A	R422A	R453A
R123	R406A	R422B (NU22B)	R454A
R133ZD	R407A	R422C (One shot)	R454B
R1234YF	R407B	R422D	R454C
R1324ZE	R407C	R423A	R455A
R124	R407E	R424A	R458A
R125	R407F	R425A	R500
R13	R407H	R426A	R501
R134A	R408A	R427A	R502
R142B	R409A	R428A	R503
R143A	R409B	R429A	R504
R152A	R410A	R430A	R507A
R22	R410B	R431A	R508A
R227EA	R411A	R432A	R508B (Suva95)
R23	R411B	R433A	R509A
R236FA	R412A	R434A (RS-45)	R510A
R245FA	R413A	R435A	R512A
R290	R414A	R436A	R513A
R32	R414B (Hotshot)	R436B	R600 (Butane)
R401A	R416A	R438A (MU99)	R600A (Isobutane)
R401B	R417A	R444A	R601 (Pentane)
R401C	R417C (Hotshot 2)	R444B	R601A (Isobutane)

## AIR SIDE PERFORMANCE

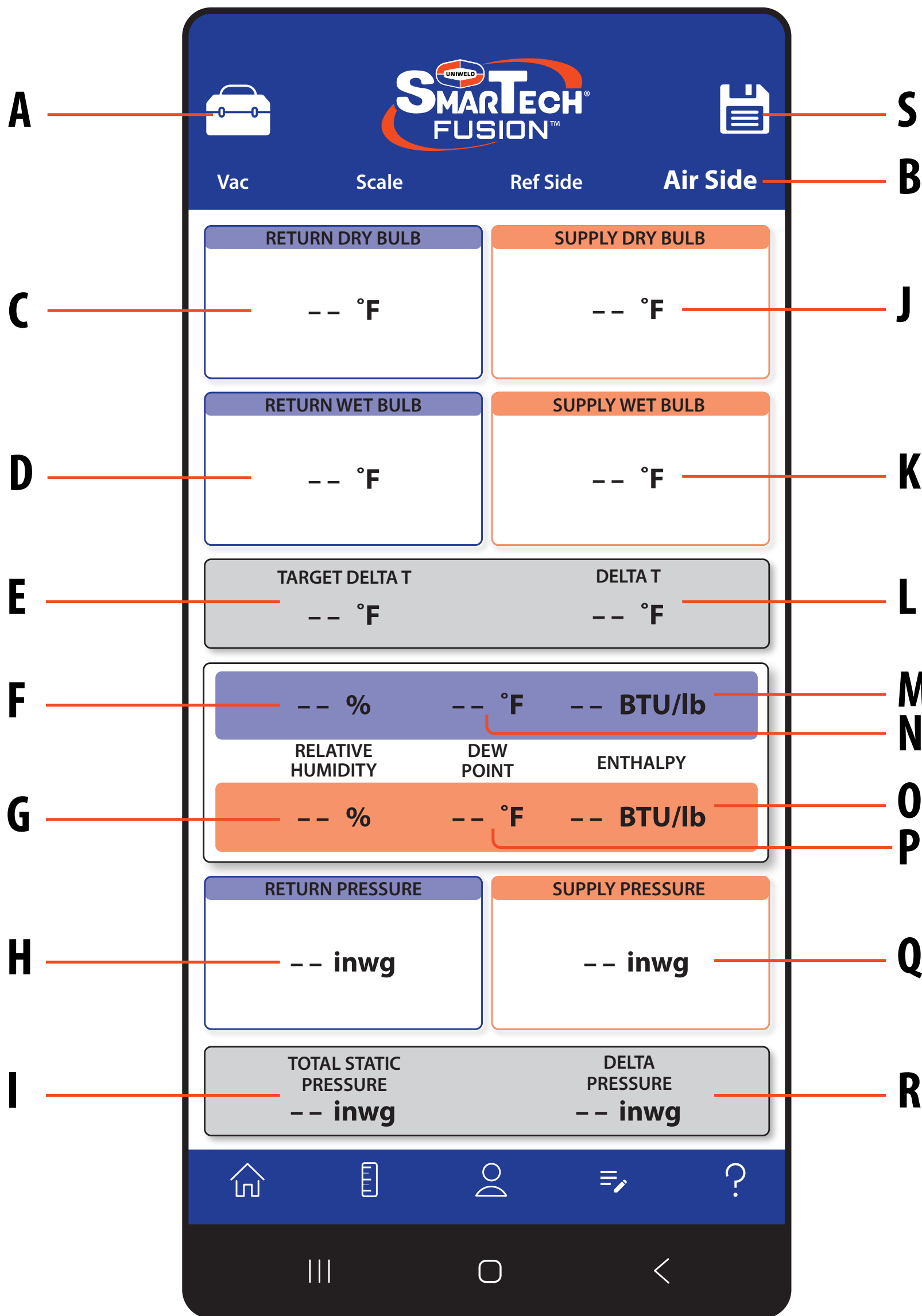

- A.** Tool Box
- B.** Air Side (tap or swipe left/right to view)
- C.** Return Dry Bulb
- D.** Return Wet Bulb
- E.** Target Delta T
- F.** Return Relative Humidity
- G.** Supply Relative Humidity
- H.** Return Pressure
- I.** Total Saturation Pressure
- J.** Supply Dry Bulb
- K.** Supply Wet Bulb
- L.** Delta T
- M.** Return Enthalpy
- N.** Return Dew Point
- O.** Supply Enthalpy
- P.** Supply Dew Point
- Q.** Supply Pressure
- R.** Delta Pressure
- S.** Save Results for Report

# APP OVERVIEW

## AIR SIDE TOOL CONNECTION

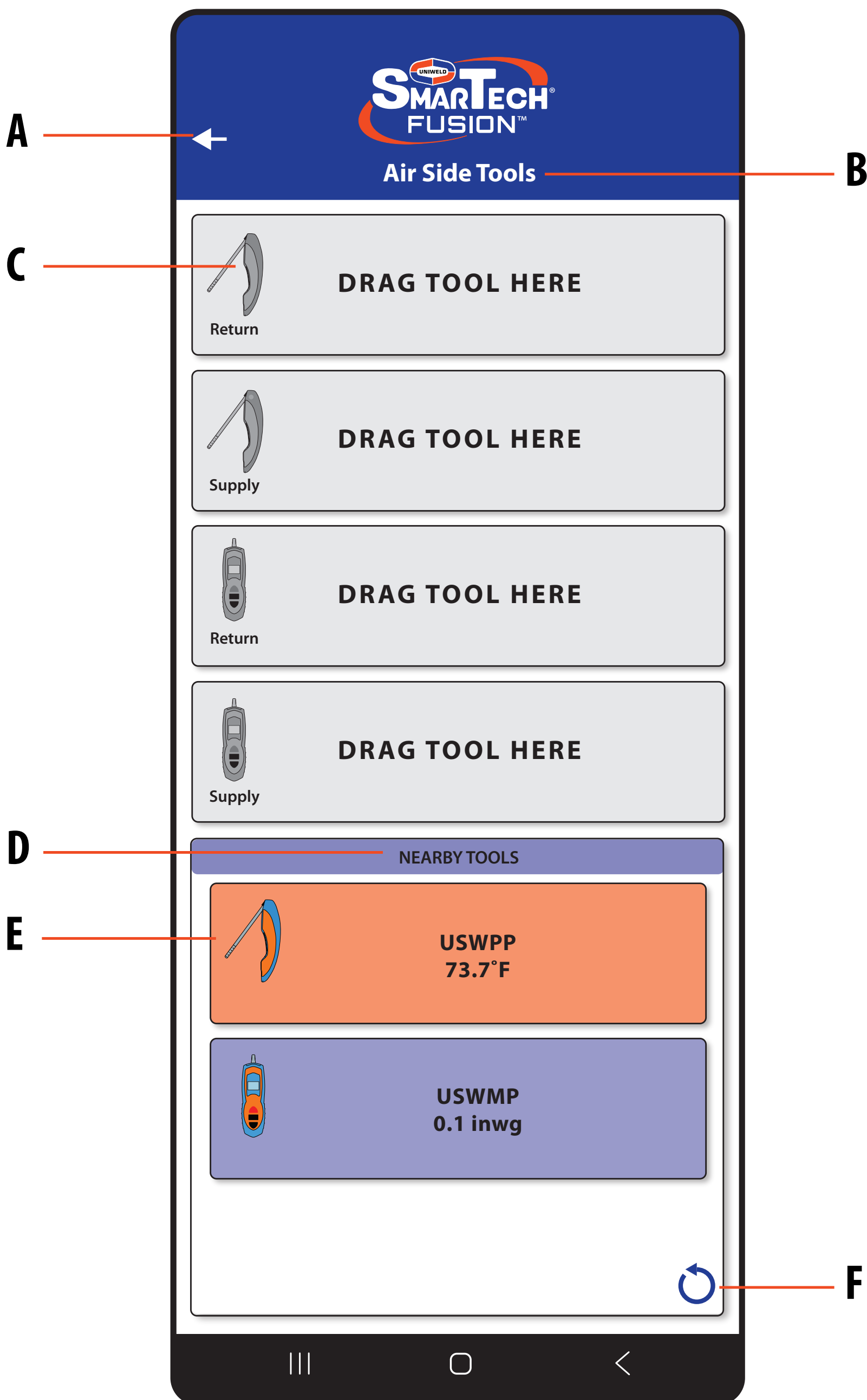

- A. Back
- B. Air Side Tools
- C. Drag tool here for connection
- D. Nearby Tools
- E. Tool found but not assigned
- F. Refresh nearby tools

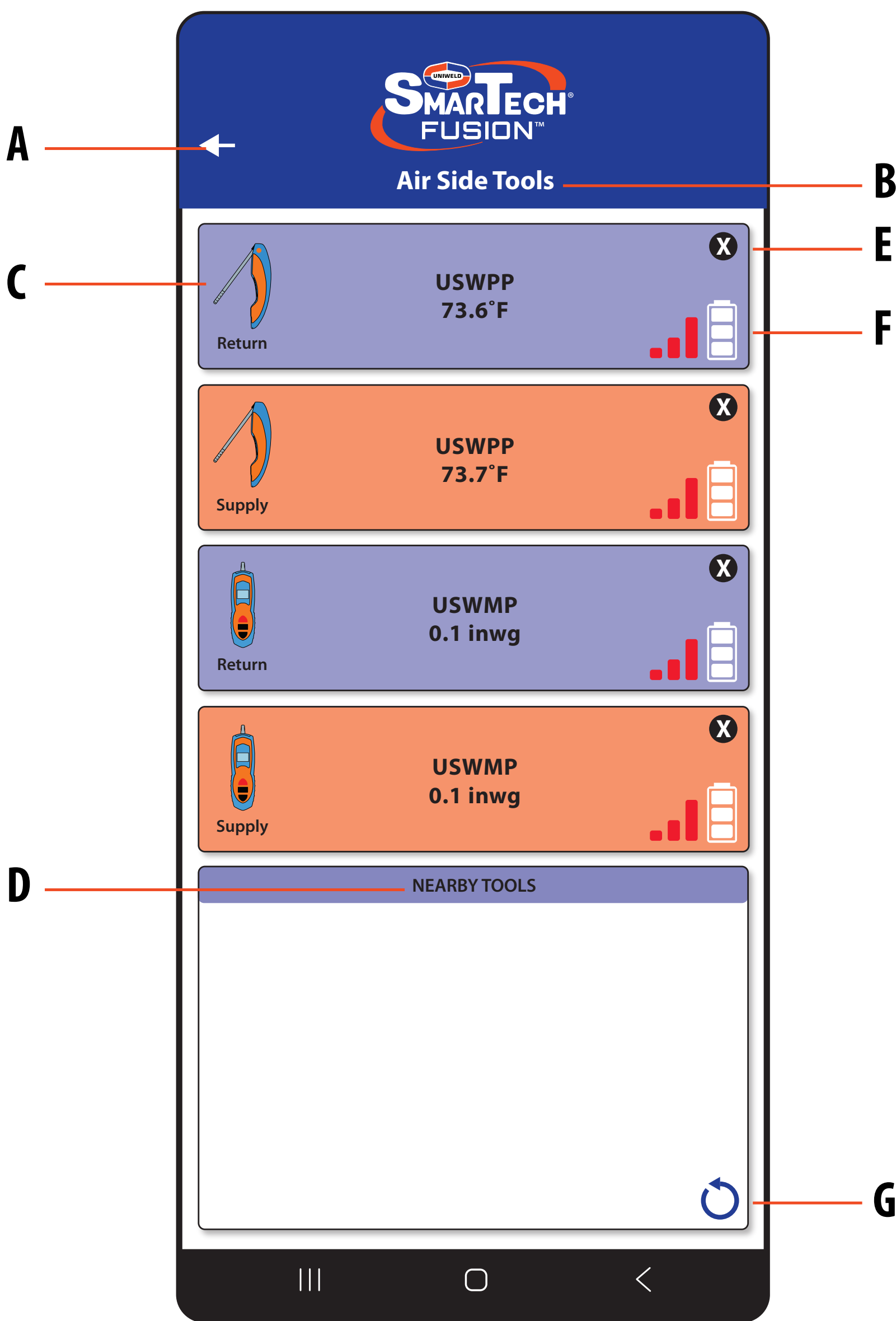

- A. Back
- B. Air Side Tools
- C. Tool assigned
- D. Nearby Tools
- E. Forget Tool
- F. Battery level and signal strength
- G. Refresh nearby tools

# APP OVERVIEW

## UNITS SCREEN

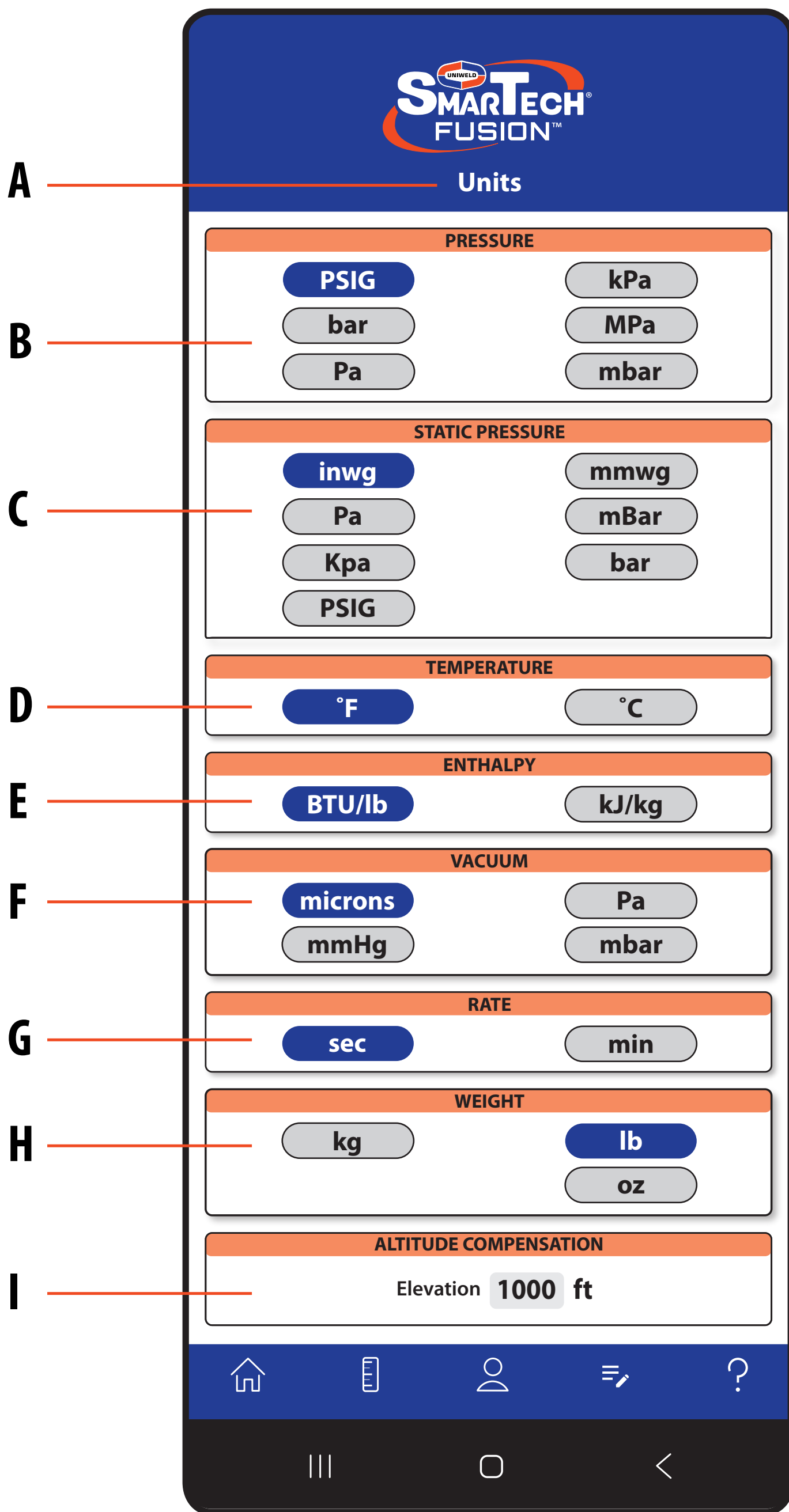

- A. Units
- B. List of Pressure Units (Unit selected will reflect in the entire app – Default PSIG)
- C. List of Static Pressure Units (Default inwg)
- D. Temperature (Default °F)
- E. Enthalpy (Default BTU/lb)
- F. Vacuum (Default microns)
- G. Rate (Default sec)
- H. Weight (Default lb and oz)
- I. Elevation

## USER INFO SCREEN

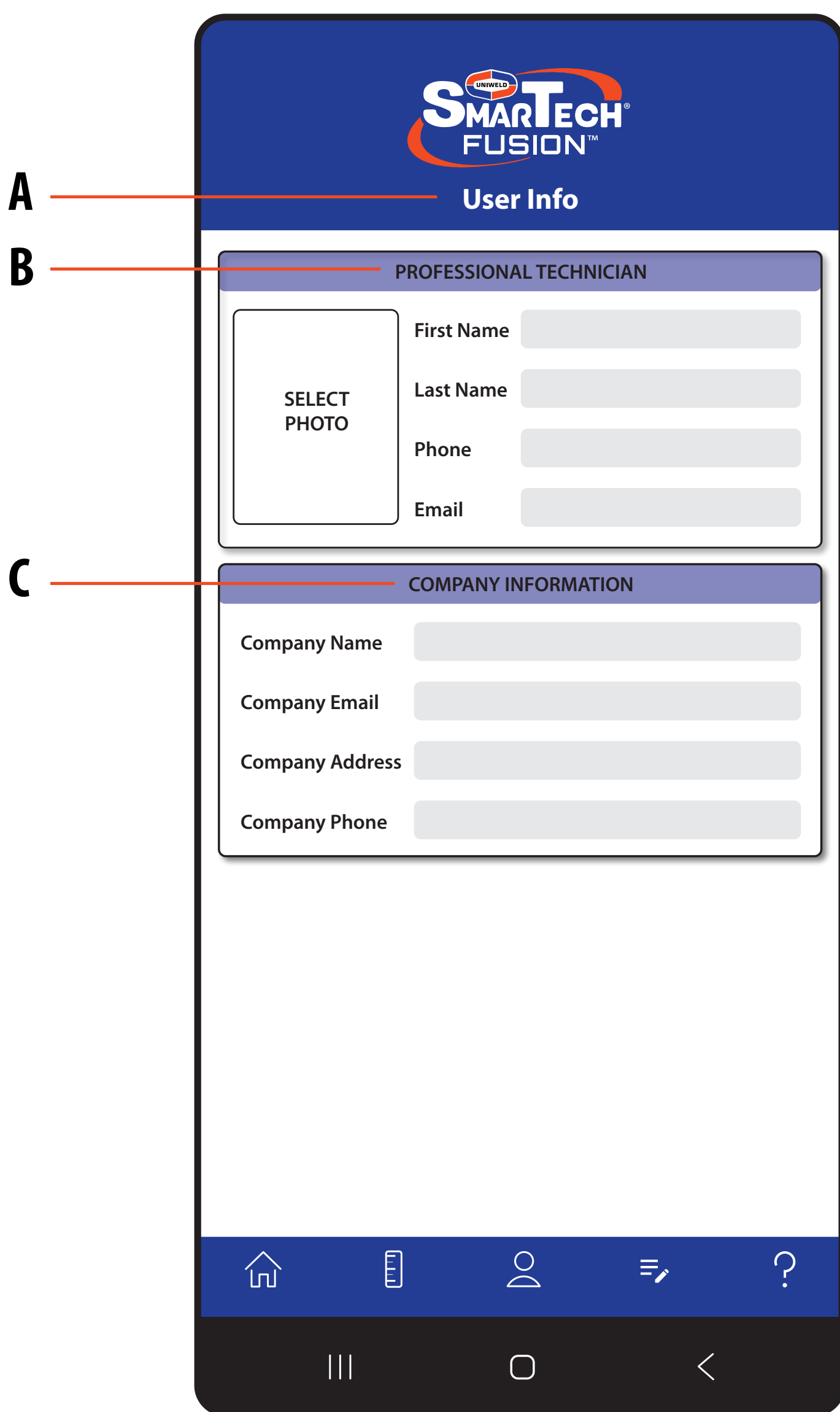

- A. User Info
- B. Professional Technician Information
- C. Company Information

# APP OVERVIEW

## REPORT SCREEN

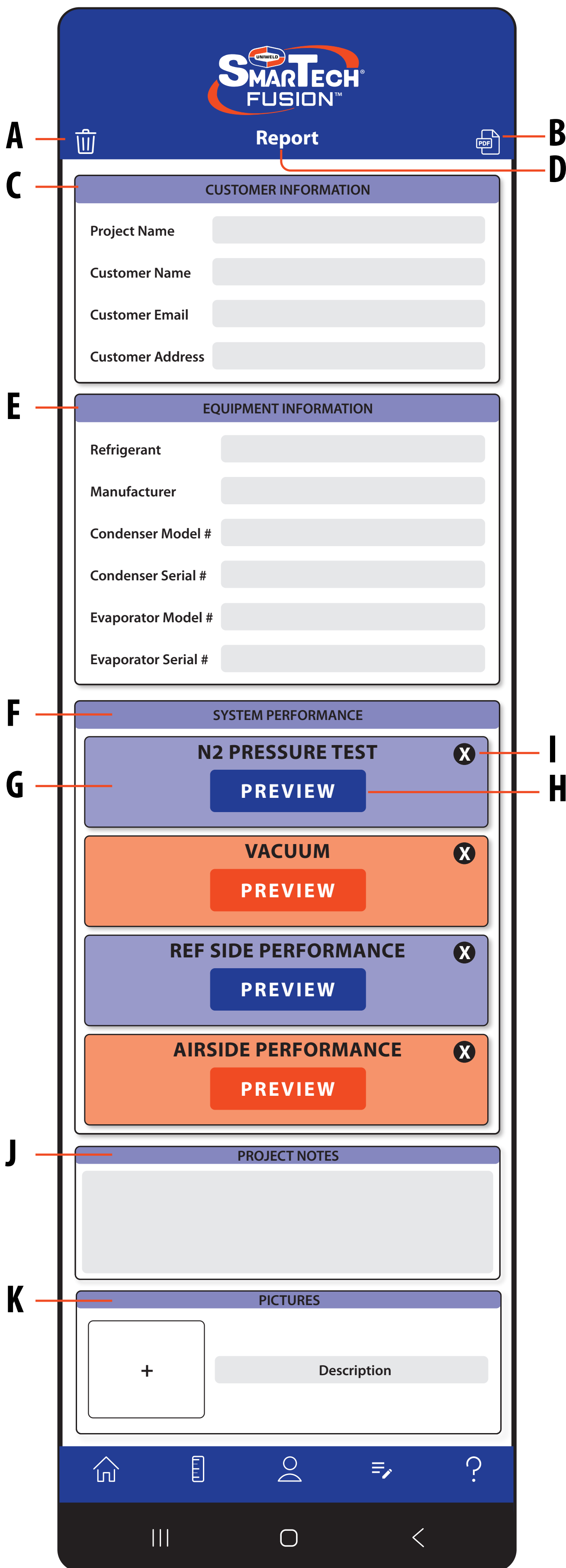

Illustration A

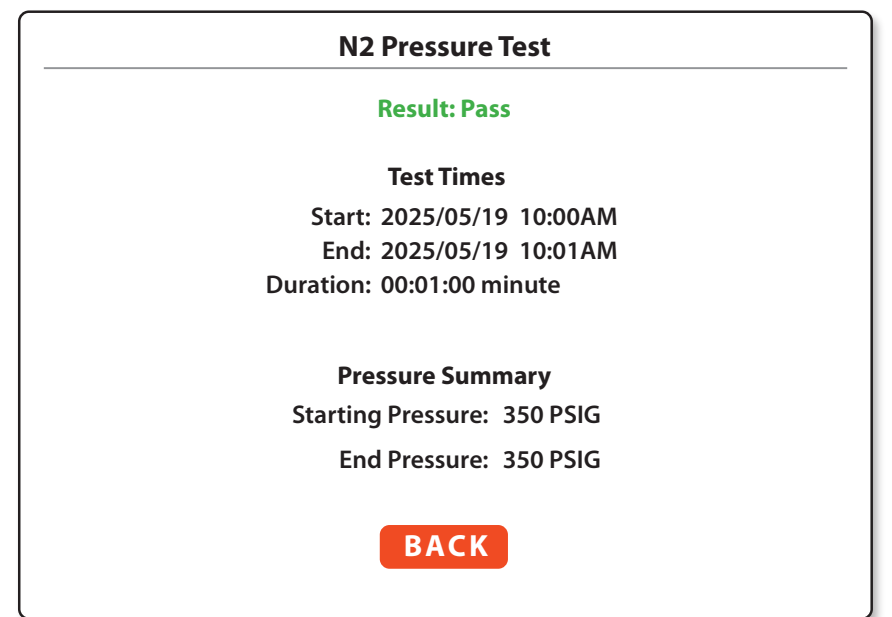

Illustration B

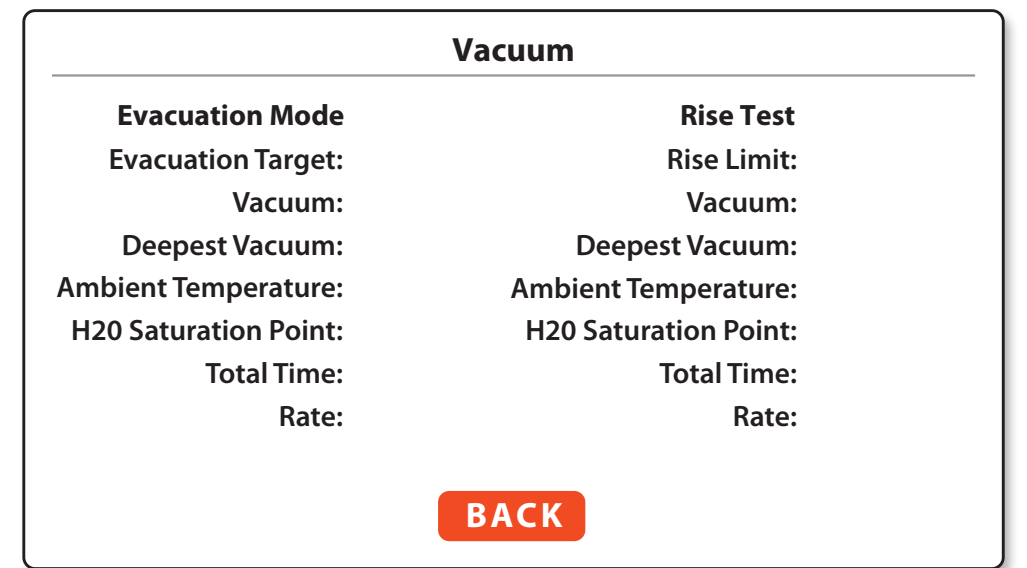

Illustration C

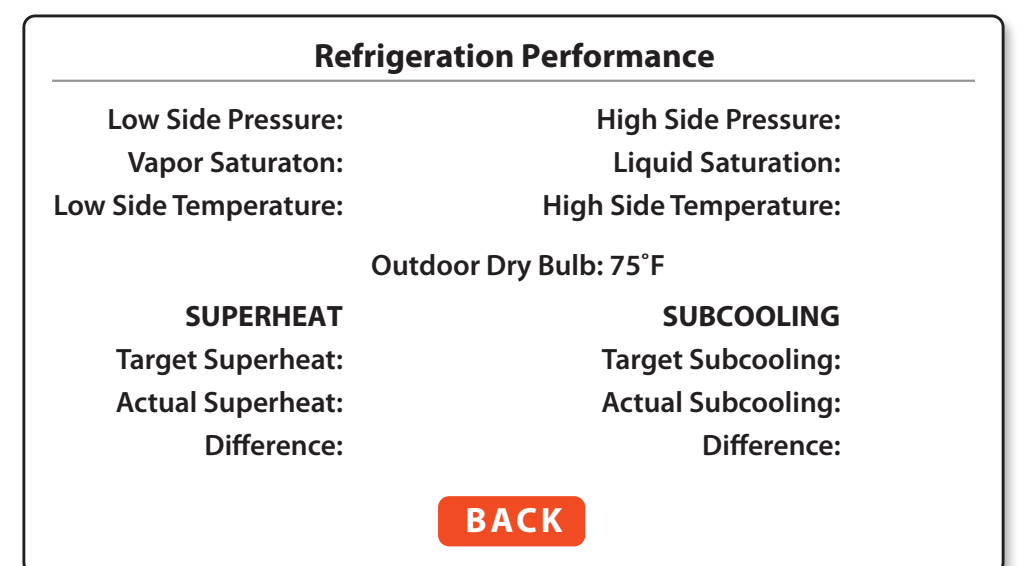

Illustration D

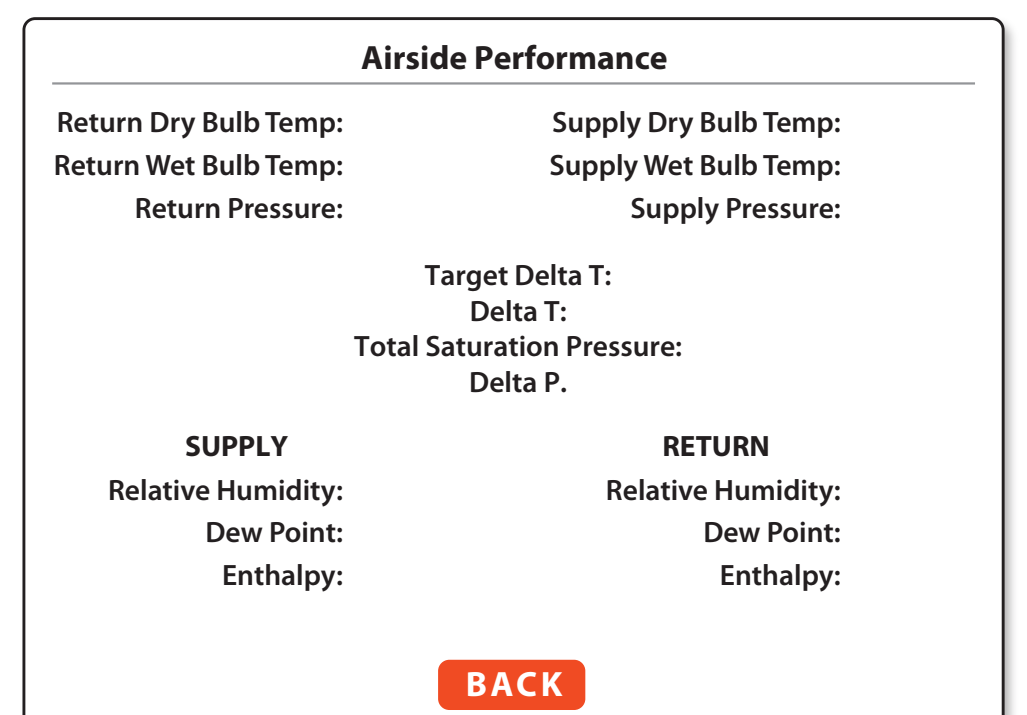
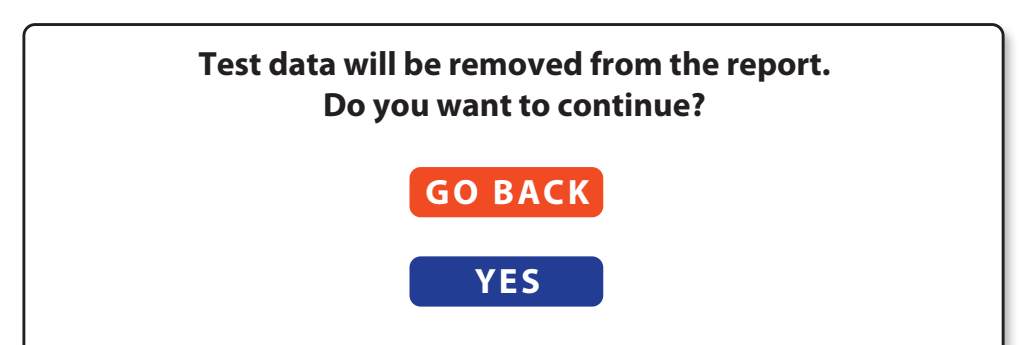

Illustration E



- A.** Clear All (clicking this icon opens Illustration E pop-up that allows the user to verify the command before deleting all entries)
- B.** Export as PDF
- C.** Customer Information
- D.** Report
- E.** Equipment Information
- F.** System Performance (this section displays all saved results collected from each test screen or test performed)
- G.** N<sub>2</sub> Pressure Test Results
- H.** Preview Test/Saved Results (clicking this will open Illustration A/B/C/D pop-up to preview the Test/Saved Results)
- I.** Remove Test/Saved Results from Report
- J.** Projects Notes
- K.** Pictures (this section allows user to add pictures with description to the report)

# APP OVERVIEW

## ? SUPPORT SCREEN

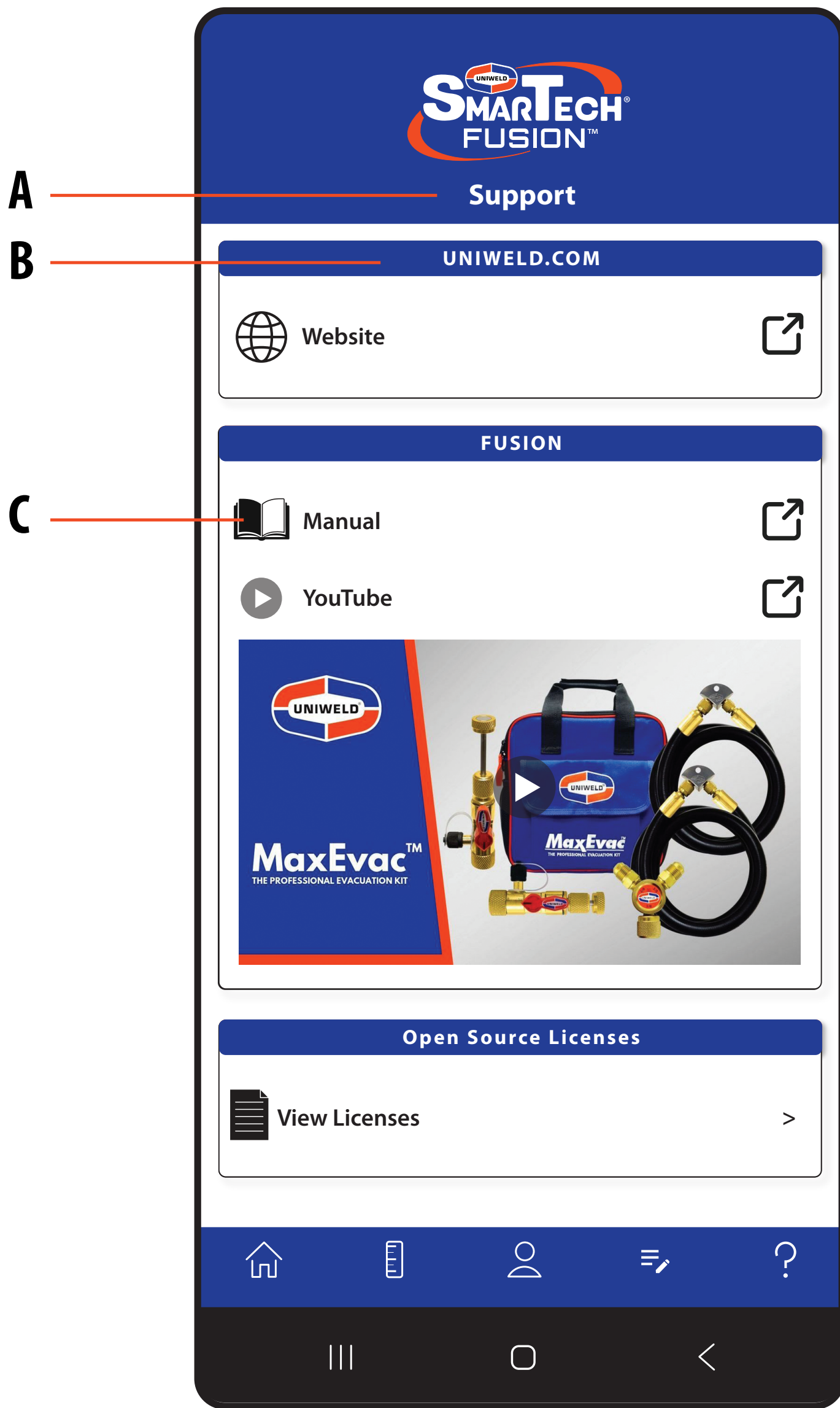

- A. Support
- B. Uniweld Webpage
- C. User Manual

For additional support regarding the APP functionality, troubleshooting, privacy policy, software terms of use, or any question related to FUSION Probes, Product or APP. Please contact:



2850 Ravenwood Road, Fort Lauderdale, FL 33312 U.S.A.

Customer Service 1-800-323-2111 • 954-584-2000

Fax: 954-587-0109

[www.uniweld.com](http://www.uniweld.com)

Email: [info@uniweld.com](mailto:info@uniweld.com) • [fusion@uniweld.com](mailto:fusion@uniweld.com)

## FCC and IC STATEMENT

This equipment has been tested and found to comply with the limits for a Class B digital device, pursuant to part 15 of the FCC Rules. These limits are designed to provide reasonable protection against harmful interference in a residential installation. This equipment generates, uses and can radiate radio frequency energy and, if not installed and used in accordance with the instructions, may cause harmful interference to radio communications. However, there is no guarantee that interference will not occur in a particular installation. If this equipment does cause harmful interference to radio or television reception, which can be determined by turning the equipment off and on, the user is encouraged to try to correct the interference by one or more of the following measures:

- Reorient or relocate the receiving antenna.
- Increase the separation between the equipment and receiver.
- Connect the equipment into an outlet on a circuit different from that to which the receiver is connected.
- Consult the dealer or an experienced radio/TV technician for help.

This equipment complies with FCC/IC RSS102 radiation exposure limits set forth for an uncontrolled environment.

This device complies with Industry Canada license-exempt RSS standard(s). Operation is subject to the following two conditions: (1) this device may not cause interference, and (2) this device must accept any interference, including interference that may cause undesired operation of the device.

Under Industry Canada regulations, this radio transmitter may only operate using an antenna of a type and maximum (or lesser) gain approved for the transmitter by Industry Canada. To reduce potential radio interference to other users, the antenna type and its gain should be so chosen that the equivalent isotropically radiated power (e.i.r.p.) is not more than that necessary for successful communication.

## FCC AND IC NOTICE

This device complies with Part 15 of the FCC rules and Industry Canada license-exempt RSS 247. Operation is subject to the following two conditions: (1) This device may not cause harmful interference; and (2) this device must accept any interference received, including interference that may cause undesired operation.

## DISPOSAL

**!** **CAUTION:** This symbol indicates that equipment and its accessories shall be subject to separate collection and correct disposal.



## CLEANING

Periodically clean your probes case using a damp cloth. **DO NOT** use abrasive, flammable liquids, cleaning solvents, or strong detergents as they may damage the finish, impair safety, or affect the reliability of the structural components.

### Cleaning the WVG2 Vacuum Sensor

If the vacuum sensor becomes contaminated with oil, follow this procedure:

1. Power off the WVG2
2. Carefully shake the gauge to remove any large quantities of oil from the sensor
  1. Apply a few drops of rubbing alcohol inside the vacuum port  
**(DO NOT INSERT ANY OBJECT INTO PORT, AS THIS WILL PERMANENTLY DAMAGE THE SENSOR)**
  4. Place your finger over the port and shake for 30 seconds
  5. Remove your finger and allow alcohol to flow out the sensor part
  6. Repeat steps 3 to 5 at least three times
  7. Allow the sensor to air dry over at least an hour, or pull a vacuum on the sensor to to. Dry it more quickly
8. Power on the WVG2, which should be ready for use.

**NOTE:** It is important to remove all the vapors from the sensor, either through air-drying or via vacuum. Any remaining vapors will cause an incorrect reading

## CLEANING MANOMETER

Periodically clean your meter's case using a damp cloth. **DO NOT** use abrasive, flammable liquids, cleaning solvents, or strong detergents as they may damage the finish, impair safety, or affect the reliability of the structural components.

Keep pressure ports clean and free of grease and other deposits; clean with a moist cloth as required.

## STORAGE

Remove the batteries when instrument is not in use for a prolonged period of time. Do not expose to high temperatures or humidity. After a period of storage in extreme conditions exceeding the limits mentioned in the General Specifications section, allow the instrument to return to normal operating conditions before using it.

## WARRANTY

The UNIWELD FUSION is warranted to be free from defects in materials and workmanship for a period of 1 year from the date of purchase. If within the warranty period your instrument should become inoperative from such defects, the unit will be repaired or replaced at Uniweld's option. This warranty covers normal use and does not cover damage which occurs in shipment or failure which results from alteration, tampering, accident, misuse, abuse, neglect or improper maintenance. Batteries and consequential damage resulting from failed batteries are not covered by warranty.

Any implied warranties, including but not limited to implied warranties of merchantability and fitness for a particular purpose, are limited to the express warranty. Uniweld shall not be liable for loss of use of the instrument or other incidental or consequential damages, expenses, or economic loss, or for any claim or claims for such damage, expenses or economic loss.

A purchase receipt or other proof of original purchase date will be required before warranty repairs will be rendered. Instruments out of warranty will be repaired (when repairable) for a service charge

For more information on warranty and service, contact:



[www.uniweld.com](http://www.uniweld.com)

Email: [info@uniweld.com](mailto:info@uniweld.com)

1-800-323-2111

This warranty gives you specific legal rights. You may also have other rights, which vary from state to state.